

InteliLite^{NT}

InteliLite NT[®] MRS

Modular Gen-set Controller

Compact Controller for Single Operating Gen-sets

(IL-NT MRS10/11/15/16 unit)

SW version 1.0, August 2007



User guide



Table of Contents

Table of Contents	2
General guidelines.....	5
What describes this manual?	5
!! Warnings !!	5
Text	5
General description	7
Description of the controller system (with all options).....	7
What is in the package?.....	7
IL-NT RS232 communication module	7
IL-NT AOU8 gauge driver module	7
IL-NT RD Remote display	7
Remote annunciator IGL - RA15.....	7
IG IOM/PTM module	8
IG-IB Internet bridge.....	8
IL-NT Terminals.....	9
IL-NT Terminals.....	9
Recommended wiring.....	10
MRS – Wiring Diagram	10
Getting started	11
How to install.....	11
Single phase applications	15
Analog inputs.....	16
Extension modules (CAN bus) connection	21
Analog outputs	21
Inputs and outputs.....	22
Binary inputs IL-NT - default	22
Binary inputs – list	22
Binary outputs IL-NT MRS16- default	24
Binary outputs - list.....	24
Analog inputs.....	30
Setpoints.....	32
Password.....	32
Basic settings	32
Engine params	33
Engine protect	36
Gener protect	38
Date/Time.....	40
Sensor spec	41
*IOM/PTM module.....	41
*ECU-controlled engine support.....	43
Values read from ECU	45
Diagnostic messages read from ECU	45
Analog inputs.....	46
Connection description.....	47
Sensor specification	51
Background of the sensor calibration.....	51
Default sensor settings.....	51
Operator interface.....	52
Pushbuttons and LEDs, MRS10/11/15/16	52
How to select the gen-set mode ?.....	53
^When to use button <u>GCB ON/OFF</u> ?	53
Display menus.....	53
How to view measured data?.....	53
How to view and edit set points?	53
How to find active alarms ?	54

MEASUREMENT screens description	54
Chart guide to menus and pushbutton's operation	57
Function description	58
OFF mode	58
MAN mode	58
AUT mode	59
Alarm management	60
Sensor fail (FLS)	60
Warning (WRN).....	60
Shut down (SD).....	60
Voltage phase sequence detection	61
Gen-set operation states	62
List of possible alarms.....	62
History file.....	64
Remote control and data logging	65
Direct connection to the PC	65
PC software - LiteEdit	65
Modbus protocol.....	65
Remote communication.....	71
Internet connection.....	71
Recommended ISDN modem	71
Recommended GSM modem.....	71
Mobile SIM card setting.....	71
Technical data	72
Power supply.....	72
Operating conditions	72
*Low Temperature modification	72
Dimensions and weight	73
Generator	73
Binary inputs and outputs.....	73
Analog inputs.....	73
Speed pick-up input	74
D+ function	74
*CAN bus interface.....	74
IL-NT RS232 interface (optional card)	74
IL-NT AOUT8 interface (optional card)	75
IGS-PTM	75
IGL-RA15	75
IG-IB	76

General guidelines

What describes this manual?

This manual describes „MRS 10/11/15/16“ software, which is designed for single set applications.

What is the purpose of the manual?

This manual provides general information how to install and operate IntelliLite NT MRS controller.

This manual is dedicated for

Operators of gen-sets

Gen-set control panel builders

For everybody who is concerned with installation, operation and maintenance of the gen-set

!! Warnings !!

Remote control

IntelliLite^{NT} controller can be remotely controlled. In case of the work on the gen-set check, that nobody can remotely start the engine.

To be sure:

Disconnect remote control via RS232 line

Disconnect input REM START/STOP

or

Disconnect output STARTER and outputs GCB CLOSE/OPEN

Because of large variety of IntelliLite^{NT} parameters settings, it is not possible to describe any combination. Some of IntelliLite^{NT} functions are subject of changes depend on SW version. The data in this manual only describes the product and are not warranty of performance or characteristic.

Text

PAGE	(Capital letters in the frame) buttons on the front panel
<i>Break Return</i>	(Italic) set points
Generator protections	(Bold) Set point group
REMOTE START/STOP	(Capital letters) binary inputs and outputs
*Something	(Symbol * before text) valid only for IL-NT MRS15/16
^Something	(Symbol ^ before text) valid only for IL-NT MRS11/16

Note:

ComAp believes that all information provided herein is correct and reliable and reserves the right to update at any time. ComAp does not assume any responsibility for its use unless otherwise expressly undertaken.

Note:

SW and HW must be compatible (e.g. IL-NT-MRS10 firmware and IL-NT MRS10 HW) otherwise the function will be disabled. If wrong software is downloaded, message HARDWARE INCOMPATIBLE appears on controller screen. In this case use Boot load (jumper) programming – close Boot jumper and follow instructions in LiteEdit, download correct software.

!!! CAUTION !!!

Dangerous voltage

In no case touch the terminals for voltage and current measurement!
Always connect grounding terminals!
In any case do not disconnect IntelliLite^{NT} CT terminals !

Adjust set points

All parameters are preadjusted to their typical values. But the set points in the “**Basic settings**” settings group **!!must!!** be adjusted before the first startup of the gen-set.

**!!! WRONG ADJUSTMENT OF BASIC PARAMETERS
CAN DESTROY THE GEN-SET !!!**

The following instructions are for qualified personnel only. To avoid personal injury do not perform any action not specified in this User guide !!!

General description

Description of the controller system (with all options)

InteliLite^{NT}-MRS is a comprehensive controller for single generating sets. IL-NT MRS 15/16 features extended support of electronic engines and extension modules.

InteliLite^{NT} controllers are equipped with a powerful graphic display showing icons, symbols and bar-graphs for intuitive operation, which sets, together with high functionality, new standards in Gen-set controls.

InteliLite automatically starts the Gen-set, closes the Gen-set C.B. when all conditions are met, then stops the engine on external signal or by pressing push buttons.

InteliLite^{NT} provides gas engine support without ventilation.

The key feature of InteliLite^{NT} is its easy-to-use operation and installation. Predefined configurations for typical applications are available as well as user-defined configurations for special applications.

What is in the package?

Accessories	Description	Optional / Obligatory
IL-NT MRS	InteliLite ^{NT} central unit	Obligatory
IL-NT RS232	RS232 communication card	Optional for MRS
IL-NT AOUT8	Gauge driver card	Optional for MRS
IL-NT RD	Remoted display	Optional for MRS
IGL-RA15	Remote annunciator	Optional for MRS15/16
IG-IOM/PTM	I/O extension module	Optional for MRS15/16
IG-IB	Internet communication bridge	Optional for MRS

IL-NT RS232 communication module

IL-NT RS232 is optional plug-in card to enable InteliLite^{NT} for RS232 communication. This is required for computer or Modbus connectin. Card inserts into expansion slot back on the controller.

IL-NT AOU8 gauge driver module

IL-NT AOUT8 is optional plug-in card. Through this card controller can drive up to 8 VDO style industrial/automotive gauges. Gauge type and value are configured in LiteEdit software. Any analog value from controller may be shown in that way.

IL-NT RD Remote display

IL-NT RD is remote display for controller. Remote display provides the same control and monitoring functions as controller itself . No programing of the display is required – unit is self configurable from main controller. It is connected with controller via RS232 line. Longer distances (up to 1200m) are possible when RS232/RS485 converters are used.

Remote annunciator IGL - RA15

The remote annunciator IGL-RA15 can be connected to the IL-NT unit via CAN bus. Any of the binary outputs can be configured (using LiteEdit software) to each LED diode on the RA15. The module can be also enabled or disabled using LiteEdit software.

See the documentation of RA15 for the technical and function description.

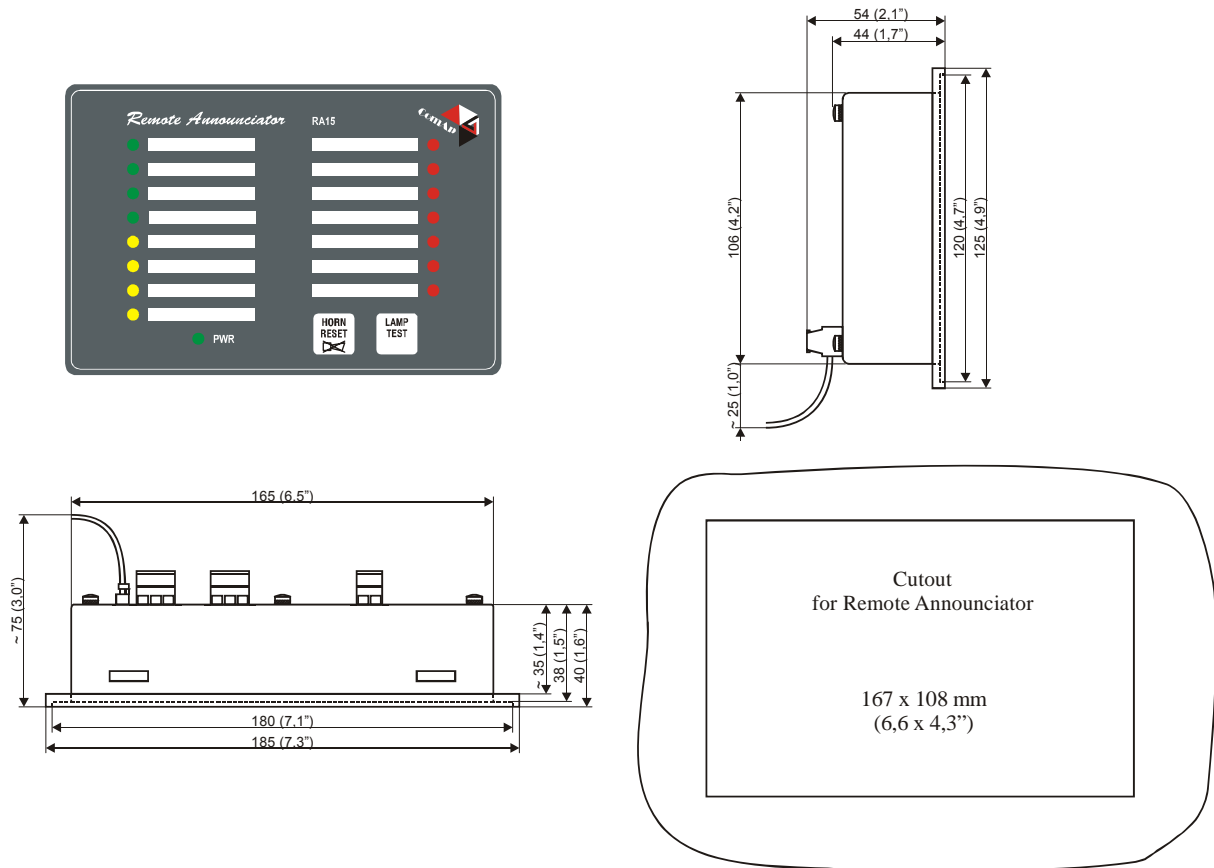

IG IOM/PTM module

IG-IOM and IGS-PTM modules are I/O extension modules equipped with 8 binary inputs, 8 binary outputs, 4 analogue inputs and one analogue output. The module can be used for AMF25 only.

- Binary inputs and outputs are configurable the same way like inputs and outputs on iL.
- Analogue inputs are configurable like iL with the limitation that the binary and tristate mode can not be used on PTM module.
- The protection of analogue IOM/PTM inputs is activated by overcrossing the limits, active only when the engine is running.
- IG-IOM analogue inputs are resistive (the same parameters like IL-NT) 0 Ω -2,4 k Ω . The module IOM is designed for especially VDO resistive sensors.
- IGS-PTM analogue inputs are configurable by jumpers to ranges 0-250 Ω , 0-100mV, 0-20mA. The module PTM is not suitable for VDO temperature sensor.

See the documentation of IGS-PTM for the technical and function description.

IG-IB Internet bridge

IG-IB Internet bridge enables IntelliLite^{NT} for Ethernet/Internet communications. It is connected to controller via RS232 line.

See the IntelliCommunication guide for further details.

IL-NT Terminals

IL-NT Terminals

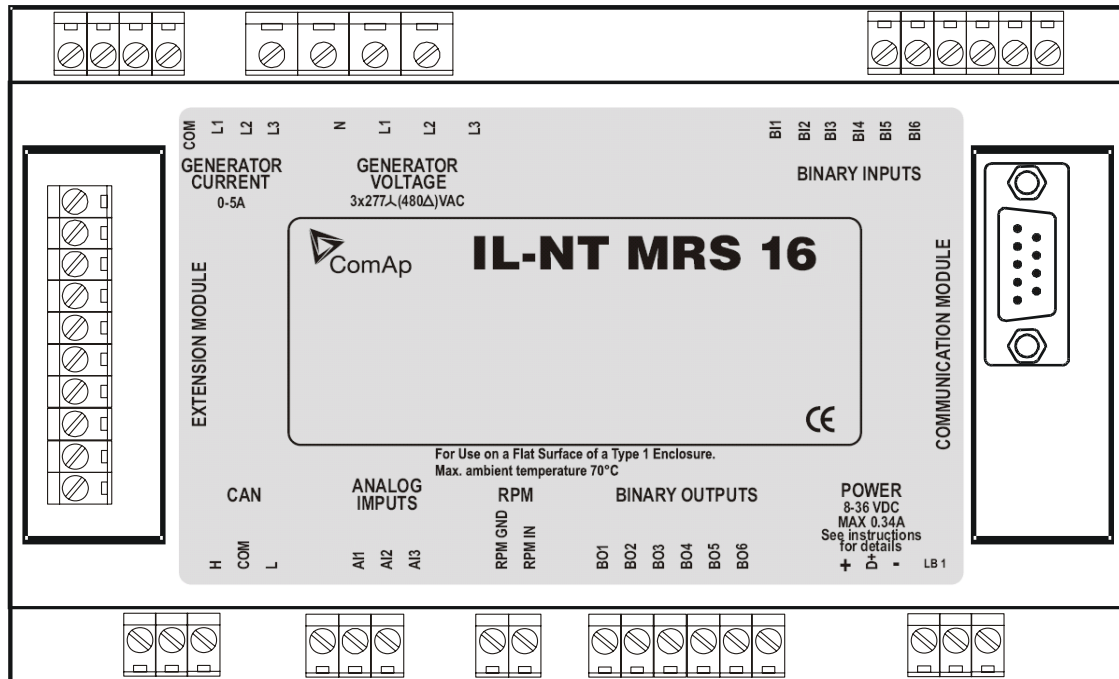

Recommended wiring

MRS – Wiring Diagram

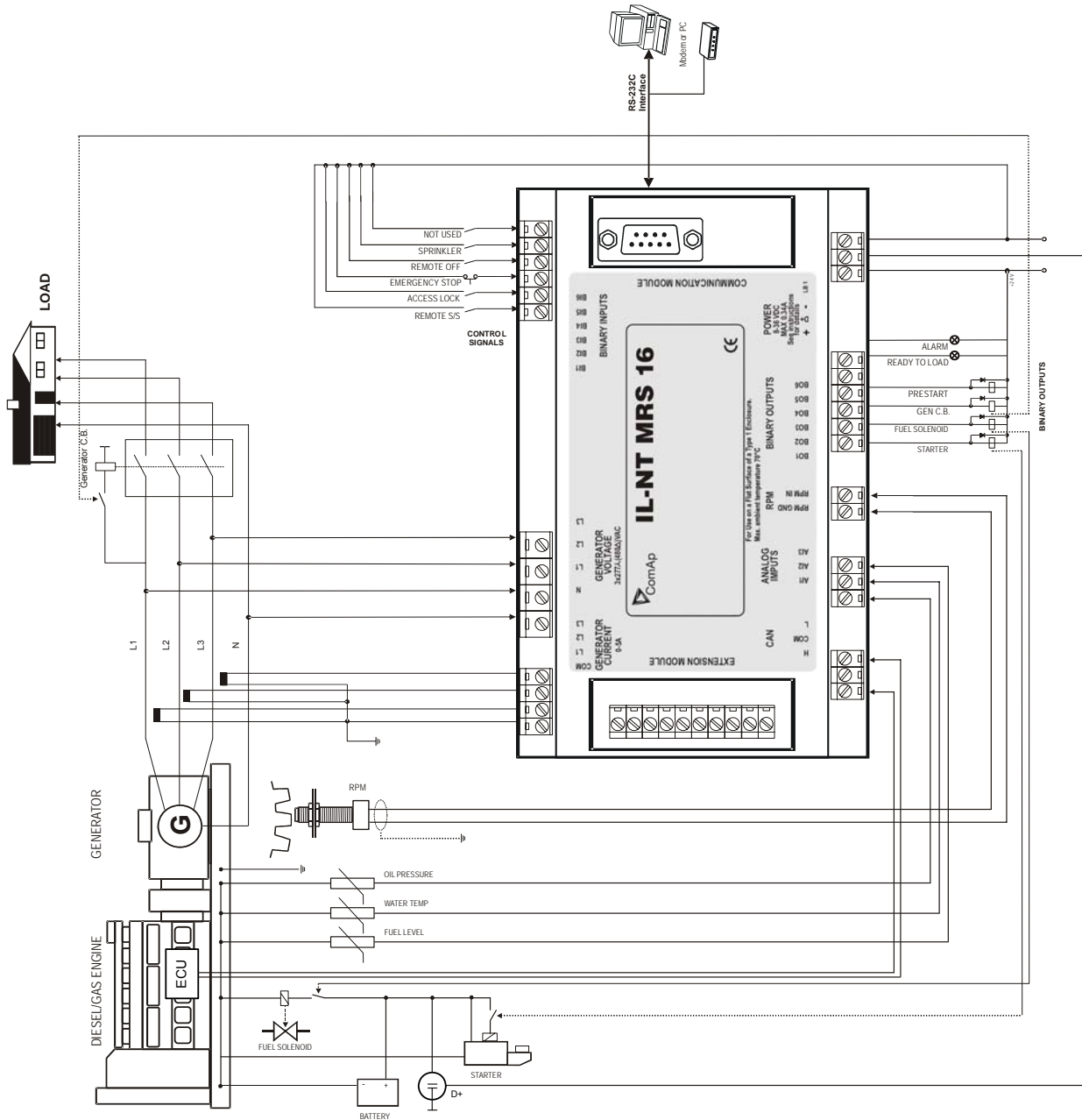

Hint:

It is possible to start Volvo and Scania engines via CAN bus. See [Engines started via CAN bus.](#)

Getting started

How to install

General

To ensure proper function:

Wiring for binary inputs and analog inputs must not be run with power cables.
Analog and binary inputs should use shielded cables, especially when length >3m.

Power supply

To ensure proper function:

Use min. power supply cable of 1.5mm²

Maximum continuous DC power supply voltage is 36VDC. Maximum allowable power supply voltage is 39VDC. The IntelliLite's power supply terminals are protected against large pulse power disturbances. When there is a potential risk of the controller being subjected to conditions outside its capabilities, an outside protection device should be used.

Hint:

The IntelliLite^{NT} controller should be grounded properly in order to protect against lightning strikes!!
The maximum allowable current through the controller's negative terminal is 4A (this is dependent on binary output load).

For the connections with 12VDC power supply, the IntelliLite^{NT} includes internal capacitors that allow the controller to continue operation during cranking if the battery voltage dip occurs. If the voltage before dip is 10V, after 100ms the voltage recovers to 7 V, the controller continues operating. During this voltage dip the controller screen backlight can turn off and on but the controller keeps operating. It is possible to further support the controller by connecting the external capacitor and separating diode:

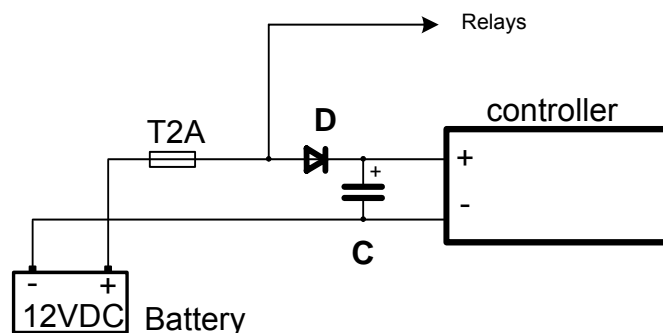

The capacitor size depends on required time. It shall be approximately thousands of microFarads.

The capacitor size should be

5 000 microFarad to withstand 150ms voltage dip under following conditions:

Voltage before dip is 12V, after 150ms the voltage recovers to min. allowed voltage, i.e. 8V

Or by connecting special I-LBA module:

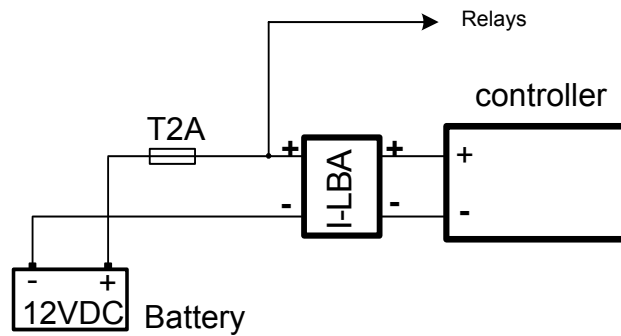

Note:

I-LBA may not eliminate voltage drop when used with low temperature (-40°C) version of controller and display heating element is on (below 5°C). Current drain of heating element exhausts LBA capacitors very fast.

Power supply fusing

A one-amp fuse should be connected in-line with the battery positive terminal to the controller and modules. These items should never be connected directly to the starting battery.

Fuse value and type depends on number of connected devices and wire length.

Recommended fuse (not fast) type - T1A. Not fast due to internal capacitors charging during power up.

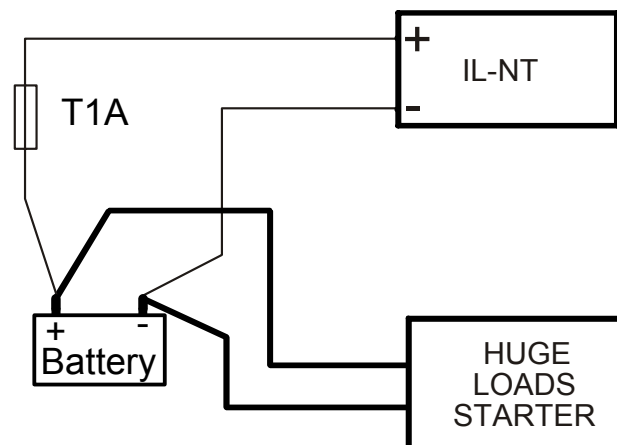

Binary output protections

Do not connect binary outputs directly to DC relays without protection diodes, even if they are not connected directly to controller outputs.

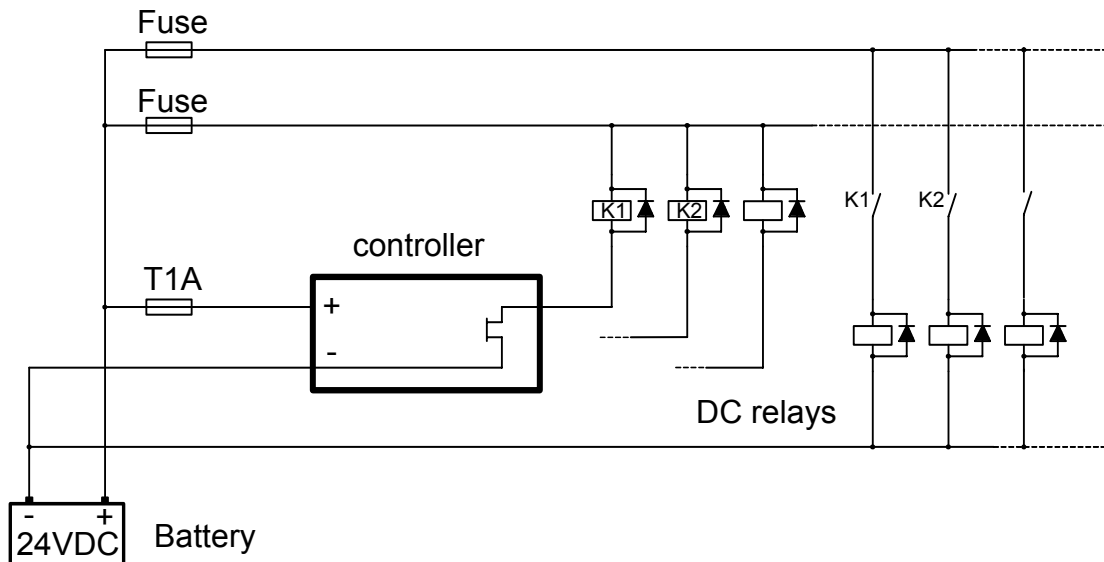

Grounding

To ensure proper function:

Use as short as possible cable to the grounding point on the switchboard

Use cable min. 2,5mm²

The “-“ terminal of the battery has to be properly grounded

Magnetic pick-up

To ensure proper function:
Use a shielded cable

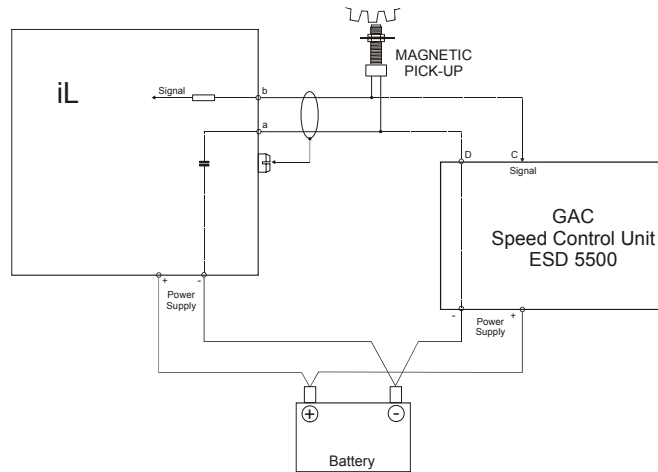

Be aware of interference signal from Speed governor when one speed pick-up is used.

If engine will not start:

- Check ground connection from pick-up to controllers, eventually disconnect ground connection to one of them
- Galvanically separate IntelliLite RPM input using ComAp separation transformer RPM-ISO (1:1)
- Use separate pick-up for Speed governor and IntelliLite^{NT}

Hint:

In some cases the controller will measure a RPM value even though the gen-set is not running: RPM is measured from the generator voltage (Gear teeth = 0)

IL-NT is measuring some voltage value on input terminals due to open fusing.

If RPM > 0 the controller will be put into a Not ready state and the engine will not be allowed to start.

Current measurement

To ensure proper function

Use cables of 2,5mm²

Use transformers to 5A

Connect CT according to following drawings

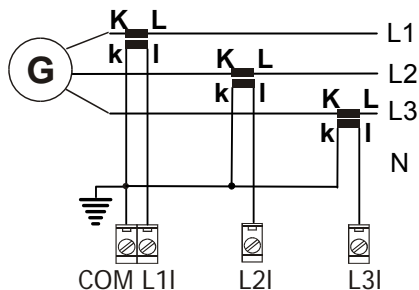

Voltage measurement

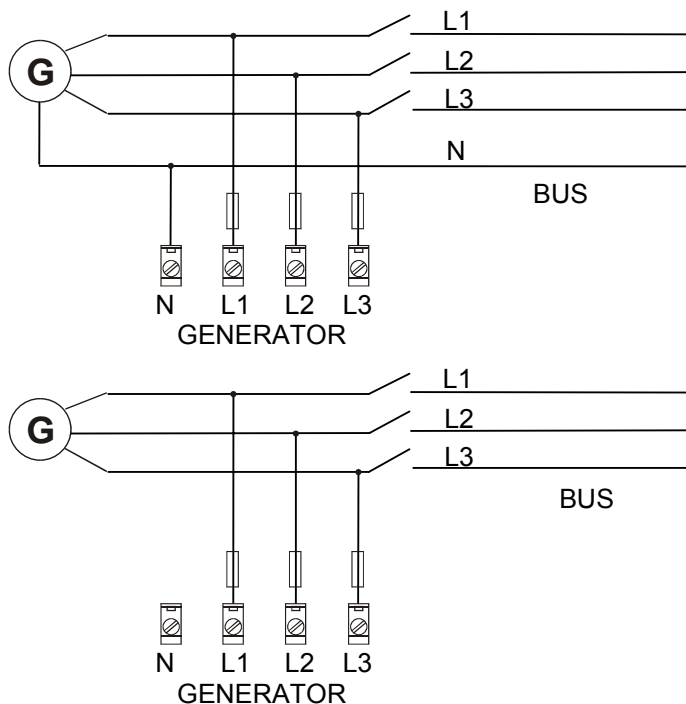

Hint:

No separation transformers for three wires voltage connection (without N) are needed.
Switchboard lighting strikes protection according standard regulation is expected !!!

Single phase applications

There is not a separate archive file for single-phase applications. Use standard all archives.

Recommended wirings

Generator (and mains) single-phase voltage has to be connected to all three-voltage terminals L1, L2 and L3. Generator current has to be connected to L1I and COM terminals only.

Voltage measurement

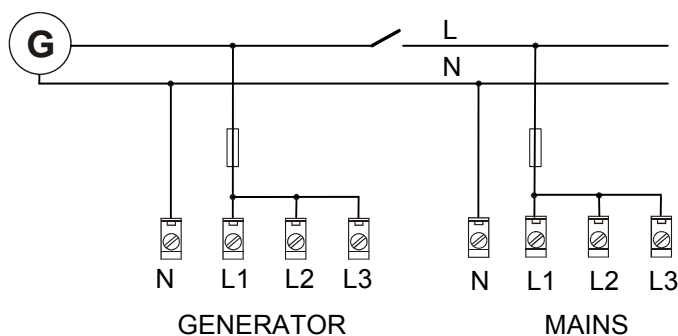

Hint:

Switchboard lighting strikes protection according standard regulation is expected !!!

Current measurement

To ensure proper function

Use cables of 2,5mm²

Use transformers to 5A

Connect CT according to following drawings. Terminals L2I and L3I are opened.

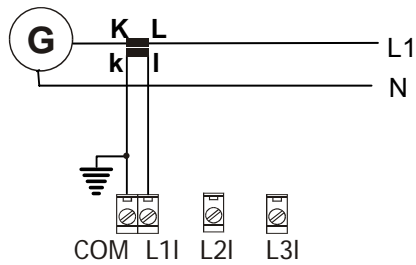

Set points adjustment

To run a single-phase application, the following set points have to be set:

Gener protect: *Curr unbal* to 200 %
Gener protect: *Curr unbal del* to 60,0 s

Analog inputs

Three analog inputs are available on the IL-NT

Configuration

Each analog input can be configured by LiteEdit software following way.

Analog input item	LiteEdit			Possibility
Type	Type	Not used Alarm		Analog input isn't used
Analog input name	Name			Up to 14 ASCII characters
Config of input	Config	Analog Binary (not supp. by PTM) Tri-state (not supp. by PTM)		Analog measuring in specified range. Binary: open/close - threshold 750 Ω. Three-state: open/close - threshold 750 Ω, Failure <10 Ω or > 2400 Ω
Physical dimension	Dim	bar,%, °C, ...		Up to 3 ASCII characters (Valid only for analog inputs)
Polarity	Contact type	NC NO		Valid only for binary and three-state inputs Valid only for binary and three-state inputs
Protection direction	Protection	Over		Overstep. Sensor fail does not activate protection.
		Over+Fls		Overstep and Sensor fail activates protection.
		Under		Under step. Sensor fail does not activate protection.
		Under+Fls		Under step and Sensor fail activates protection.
Sensor characteristic	Sensor	Curve A	IL, IOM,PTM	User curve A
		Curve B	IL, IOM,PTM	User curve B
		Curve C	IL, IOM,PTM	User curve C
		PT 1000	IL, IOM	IEC 751, range -20 to 120 °C
		NI 1000	IL, IOM	DIN 43760, range -20 to 120 °C
		VDO Temp	IL, IOM	°C
		VDO Press	IL, IOM,PTM	See chapter sensor specification
		VDO Level	IL, IOM,PTM	See chapter sensor specification
4-20mA/100	IL, IOM	20mA/10.0Bar, ext. R 120 Ω		
4-20mA/ 60	IL, IOM	20mA/6.0Bar ext R 120 Ω		

		Pt100 Ni100 0-20mA/100 4-20mA/100 0-100mV/100	PTM PTM PTM PTM PTM	0-20mA/10.0Bar 4-20mA/10.0Bar
Decimal points	Dec	0, 1, 2		Number of decimal points (Valid only for analog inputs)

User Curve A, B, C are adjustable in LiteEdit.

Each Analog input has separate set points for two level alarm setting. Analog input alarm levels and delay adjust in **Protection** or **Engine protection** group.

Default current sensor characteristic with external resistor 120 ohms

	4-20mA/100		0-20mA/100		0-20mA/-20 - 120°C
Primary	Converted	Note 1	Note 2	Note 3	Note 4
120			0 mA	0%	-20°C
170	0	0%	4 mA	20%	8°C
200	13				22°C
230	25	25%	8 mA	40%	36°C
280	38				50°C
330	50	50%	12 mA	60%	64°C
390	63				78°C
460	75	75%	16 mA	80%	92°C
560	88				106°C
690	100	100%	20 mA	100%	120°C

Note 1 - % range for 4-20 mA input

Note 2 - range 0-20 mA

Note 3 - % range for 0-20 mA input

Note 4 - characteristic 0-20 mA / -20 - +120 °C

Connection of IL-CU analog inputs

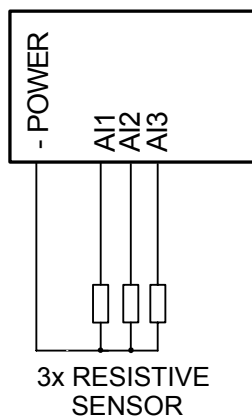

Standard connection of three resistive sensors to analog inputs.

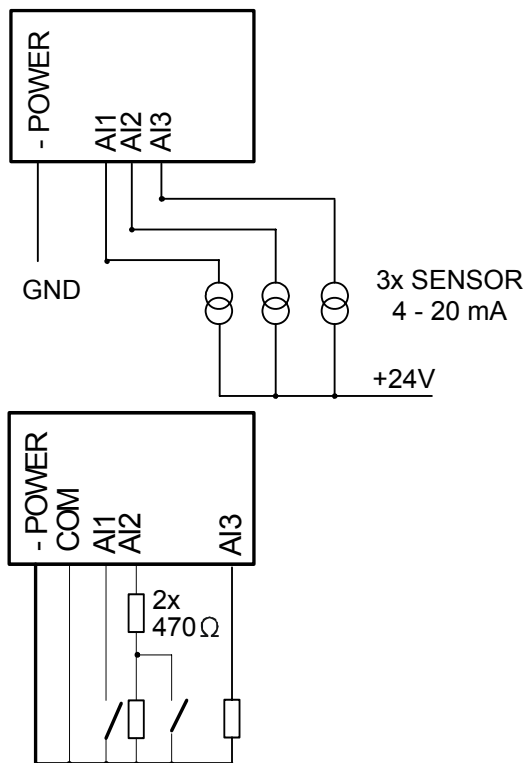

Three current output sensors connection to Intelilite.

Set jumpers for current measurement

Mixed connection of Intelilite analog inputs:

AI1 – binary input
AI2 – three state input
AI3 – analog resistive input

Analog inputs are designed for resistive sensors with resistance in range of 0Ω to 2,4kΩ. To ensure a proper function use shielded cables, especially for length over >3m.

Current output transducers

IL-NT analog inputs are mainly designed for resistor sensors.

In special case transducers to 4-20mA output can be used for oil measuring (10.0Bar or 6.0Bar). Use predefined 4-20mA/100 or 4-20mA/60 sensors.

This method reduces the input resolution by less than 50%. Some types of transducers are not suitable for connection to Intelilite analog inputs because of influencing by Intelilite analog input.

As binary input

Open, close state are detected, threshold level is 750 Ω.

As three state input

Open, close and failure state are detected. Threshold level is 750 Ω, failure is detected when circuit resistance is <10 Ω or > 2400 Ω.

Hint:

Protections on binary and three state inputs are following:

<i>IL-NT:</i>	AI1	Shutdown	<i>IG-IOM:</i>	AI1	Shutdown
	AI2	Shutdown		AI2	Shutdown
	AI3	Warning		AI3	Shutdown
				AI4	Shutdown

Unused analog inputs

Configure Type = Not used

Example of analog input configuration

Configure Oil press input for measuring in Bar, VDO oil pressure sensor, range 0 to 10.0 bars. Alarm protection level set to 3.5 bars, shut down level 1.2 bars.

Start LiteEdit and select – Controller - Configuration – Modify – Oil Press.

Set configuration for Oil Press analog input:

Type: selection between Not used and Alarm

„Not used“ – analog input isn't used

„Alarm“ – analog input is used

Set to: Alarm

Config: selection between Analog, Binary Tri-state input.

„Analog“ – resistor sensor is connected to Analog input.

„Binary“ – open/close contact is connected between Analog input and COM terminal

Analog input detects only open/close state.

„Tri-state“ – open/close contact is connected parallel to one of two serial resistors between Analog input and COM terminal.

Set to: Analog

Dim: Physical dimension of measured value (°C, %, Bar, ..) Maximal dimension length is three characters.

Set to: Bar

Contact type: selection of polarity only when analog input is configured as Binary or Tri-state. When is analog input configured as analog this setting has no sense.

„NC“ – polarity of binary or tri-state input

„NO“ – polarity of binary or tri-state input

Sensor: selection of sensor characteristic

„Unused input“ - when Analog input is not used. On the IntelliLite screen is displayed „#####“ value, no alarm is detected.

„Curve A“ – User curve A is defined in LiteEdit (default VDO temperature sensor)

„Curve B“ – User curve B is defined in LiteEdit (default VDO pressure sensor)

„Curve C“ – User curve C is defined in LiteEdit (default VDO fuel level sensor)

„Pt1000“ – PT1000 sensor characteristic according to IEC 751

„Ni1000“ – Ni1000 sensor characteristic according to DIN 43 760

„VDO temp“ – VDO temperature sensor

„VDO press“ – VDO pressure sensor

„VDO level“ – VDO level sensor

„4-20mA/60“ – current output sensor characteristic – requires external resistor 120 ohms between Analog input and COM terminal of Analog inputs

„4-20mA/100“ – current output sensor characteristic – requires external resistor 120 ohms between Analog input and COM terminal

Set to: VDO press

Decimals: setting of number of decimal points of measured value.

„0“ - e.g. 360 kPa, 100%, 50 °C

„1“ – e.g. 3.6 Bar

„2“ - e.g. 0.36 MPa

„3“ - e.g. 0.366 MPa

Set to: 1

When Analog input configuration is finished set the setpoints *Wrn Oil press, Sd Oil press, Oil press del* in **Engine protection** group.

Each Analog input has separate triplet of setpoints: *Wrn level, Sd level, Anl Inp del*. Names of these setpoints are fix defined

Number of decimal points of *Wrn level1* and *Sd level* is the same as the configured number of decimal points of measured value.

Binary inputs

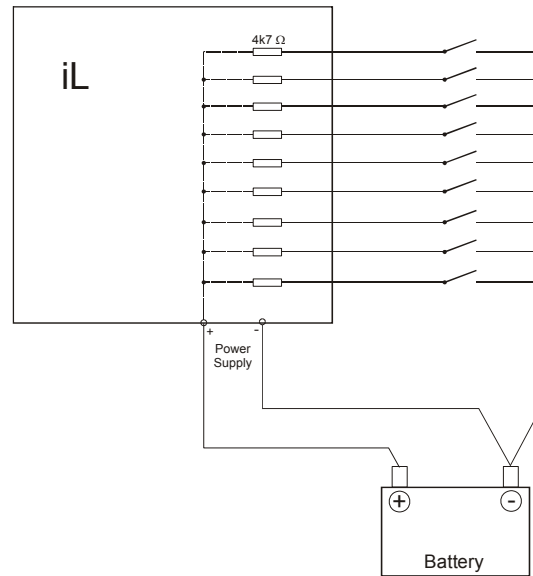

Binary outputs

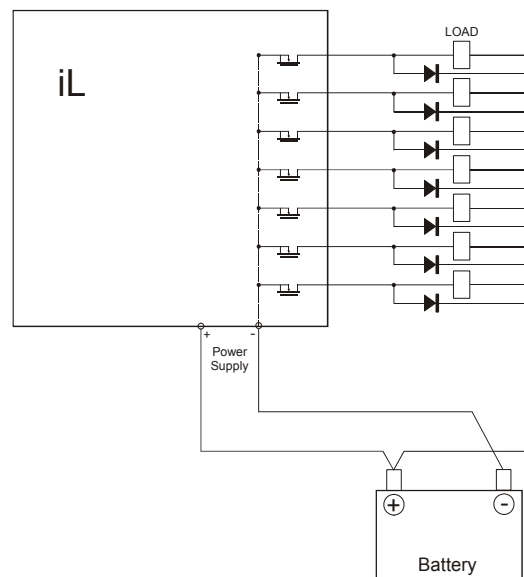

Extension modules (CAN bus) connection

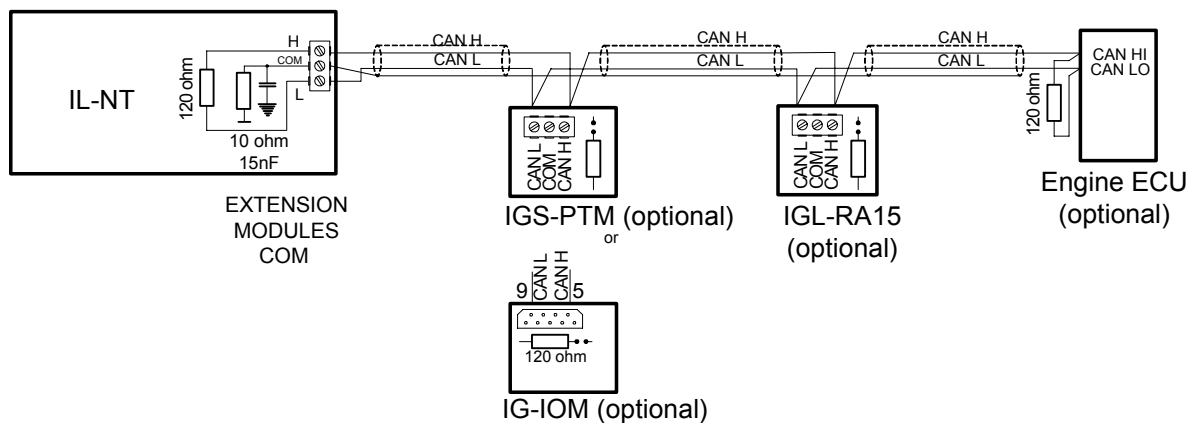

Connection rules

CAN bus line must be connected in series, from one unit to the next (no star, no cable stubs, no branches) both ends must be by the 120-ohm (internal or external) resistor terminated. Maximal CAN bus length is up to 200 meters.

For CAN data cables details see chapter Technical data – Communication interface. CAN cable shielding connect to IL-NT COM terminal.

IL-NT contains internal fix 120-ohm resistor and must be located on the CAN bus end.

New IG-IOM and IGS-PTM units contain internal jumper removable 120-ohm resistor (in older IOM types are fix resistors). To be sure check resistor presence by ohmmeter. Unit with internal resistor connect to the end of CAN line.

Following connections are supported (IOM, PTM, ECU order is not important).

IL- NT – IG-IOM – IGL-RA15 – ECU
 IL- NT – IGS-PTM – IGL-RA15 – ECU

It is possible to connect only one IG-IOM or IGS-PTM and one IGL-RA15 to IL-NT.



Use  button in LiteEdit configuration window to activate CAN (J1939) interface.

Analog outputs

Optional plug in card IL-NT AOU8 provides eighth Pulse-With-Modulation (PWM) outputs. These are intended to drive VDO style analog gauges. This is to provide visual indication of typically ECU values without installing additional sensors on the engine. PWM signal emulates sensor which would be typically mounted on the engine.

Any value from controller may be configured to the outputs. Use LiteEdit PC SW to configure corresponding sensor/gauge curve and value selection.

Inputs and outputs

Hint:

Any Binary input or output can be configured to any IL-NT controller terminal or changed to different function by LiteEdit software. There is fix 1 sec delay when any binary input is configured as protection.

Binary inputs IL-NT - default

BI1 Rem start/stop

BI2 Access lock

BI3 Emergency stop

BI4 Remote OFF

BI5 Sprinkler

BI6 Not used

Binary inputs – list

Not used

Binary input has no function. Use this configuration when Binary input is not connected.

Alarm

If the input is closed (or opened) selected alarm is activated.

Binary Alarm configuration items

Name		14 characters ASCII string
Contact type	NC	Normally closed
	NO	Normally opened
Alarm type	Warning	
	Shut down	
Alarm active	All the time	
	Engine running only	

Rem start/stop

External request for engine run. AUT mode only.

Emergency stop

If the input is opened, shut down is immediately activated. Input is inverted (normally closed) in default configuration.

Hint:

In case of controller hardware or software fail, safe stop of the engine doesn't have to be ensured. To back-up the Emergency stop function it is recommended to connect separate circuit for disconnection of Fuel solenoid and Starter signals.

Sprinkler

If the input is closed all alarms are disabled except the binary input EMERGENCY STOP and "engine overspeed protection".

- all IL alarms are detected,
- IL front panel gen-set RED LED blinks or lights,
- alarm is recorded on the IL alarm list screen,
- BUT gen-set remains running.

Hint:

Warning *SprinklActive* is indicated in the AlarmList if sprinkler mode active to inform the operator that the engine is not protected.

Access lock

If the input is closed, no setpoints can be adjusted from controller front panel and gen-set mode (OFF-MAN-AUT) cannot be changed.

Hint:

Access lock does not protect setpoints and mode changing from LiteEdit. To avoid unqualified changes the selected setpoints can be password protected.

Remote OFF

If closed, iL is switched to OFF mode (there are four modes OFF-MAN-AUT-TEST). When opens controller is switched back to previous mode.

Hint:

This binary input should be connected to schedule timer switch, to avoid start of engine.

Remote MAN

If the input is active, MAN mode is forced to the controller independently on the position of the MODE selector.

Remote AUT

If the input is active, AUT mode is forced to the controller independently on the position of the MODE selector. If another of „remote“ inputs is active, then the REMOTE AUT input has the lowest priority.

RemControlLock

If the input is active, setpoints writing or command sending from the external terminal is disabled.

Emergency manual

If the input is activated the controller behaves like when switched to OFF mode. Opens all binary outputs. There is one exception – STOP SOLENOID doesn't activate on this transition.

Detection of "running" engine and subsequent alarm message "Sd Stop fail" is blocked.

The controller shows "Emerg Man" state and the engine can not be started.

Generator current and power measurement is active in this mode, regardless of the actual state of the engine.

After the input is open again, the controller recovers to previous state and behaves according to the actual situation .

Function is active in any controller mode.

StartButton

Binary input has the same function as **Start** button on the IntelliLite front panel. It is active in MAN mode only.

StopButton

Binary input has the same function as **Stop** button on the IntelliLite front panel. It is active in MAN mode only.

FaultResButton

Binary input has the same function as **Fault reset** button on the IntelliLite front panel.

HornResButton

Binary input has the same function as **Horn reset** button on the IntelliLite front panel.

^GCB button

Binary input has the same function as **GCB** button on the IntelliLite front panel. It is active in MAN mode only.

Binary outputs IL-NT MRS16- default

BO1	Starter
BO2	Fuel solenoid
BO3	GCB Close/Open
BO4	Prestart
BO5	Ready to Load
BO6	Alarm

Binary outputs - list

Not used

Output has no function.

Starter

The closed relay energizes the starter motor.

The relay opens if:

- the “firing” speed is reached or
- maximum time of cranking is exceeded or
- request to stop comes up

Fuel solenoid

Closed output opens the fuel solenoid and enables the engine start.

The output opens if:

- EMERGENCY STOP comes or
- Cooled gen-set is stopped or
- in pause between repeated starts

Stop solenoid

The closed output energizes stop solenoid to stop the engine.

The output is active at least for *Stop time*, if the stop lasts longer, it stays active until all symptoms say the engine is stopped.

The engine is stopped if:

- RPM < 2 and
- Generator voltage < 10V and
- Oil pressure < **Engine params: StartingPoil**.

Hint:

The engine can be started anytime, if all symptoms say the engine is steady regardless of the fact the *Stop solenoid* can still be active (in that case it is deactivated before cranking).

Stop Pulse

Output is active for 1 second after *Stop solenoid* output activation. This signal is sent to ECU in case of engine stop request.

Ignition

The output closes after reaching value of CrankRPM, fixed 30RPM. Opens after stopping of the engine or in pause during repeated start.

Prestart

The output closes prior to the engine start (*Prestart*) and opens when *Starting RPM* speed is reached. During repeated crank attempts the output is closed too. The output could be used for pre-glow, pre-heat or prelubrication.

Cooling pump

The output closes when gen-set starts and opens **Engine params:** *AfterCool time* after stop of the engine.

Idle/Nominal

The output *Idle/Nominal* closes after the timer *Idle time* elapses. The *Idle time* counter starts to countdown when *Start speed* reached. The *Underspeed* protection is not evaluated during idle period. A *Start fail* protection occurs if the RPM drop below 2RPM during idle.

Air valves

Closes together with *Prestart*. Opens after the engine is stopped. Stopped engine conditions: RPM = 0, **Engine params:** *Starting Poil, D+* (when enabled).

Alarm

The output closes if :

- any warning or shutdown comes up or
- the gen-set malfunctions

The output opens if

- **FAULT RESET** is pressed

The output closes again if a new fault comes up.

Horn

The output closes if:

- any warning or shutdown comes up or
- the gen-set malfunctions

The output opens if:

- **FAULT RESET** is pressed or
- **HORN RESET** is pressed or
- Max time of HORN is exceeded (*Horn timeout*)

The output closes again if a new fault comes up.

GCB Close/Open

MRS11, 16: The output controls the generator circuit breaker.

MRS10 and 15 (GCB no GCB button):

The output closes automatically (in MAN or AUT mode) after engine is started, *MinStabtime* elapsed, and generator voltage and frequency is in limits.

GCB on coil

The output activates Generator Circuit Breaker coil.

GCB off coil

The output deactivates Generator Circuit Breaker coil.

GCB UV coil

The output controls Generator Circuit Breaker coil after voltage drop-out.

*AnInIOM1..4 Wrn

Output closes if warning alarm on the appropriate IOM/PTM analog input activates.

The output opens, if

- alarm is not active and
- **FAULT RESET** is pressed

*AnInIOM1..4 Sd

Output closes if shutdown alarm on the appropriate IOM/PTM analog input activates.

The output opens, if

- alarm is not active and
- FAULT RESET** is pressed

Ready

The output is closed if following conditions are fulfilled:

- Gen-set is not running and
- No Shut down or Slow stop alarm is active
- Controller is not in OFF mode

Ready to load

The output is closed if genset is running and all electric values are in limits no alarm is active - it is possible to close GCB or it is already closed. The output opens during cooling state.

Running

Output closes if the engine is in Running state.

Cooling

The output closes when gen-set is in Cooling state.

Supplying load

Closed when the generator current is $> 0,5\%$ of the CT ratio.

Exact formulas:

Output is closed when the current at least in one phase is for 1 sec over $CT\ ratio/200+2$

Output is opened when the current in all three phases is for 1 sec below $CT\ ratio/200+2$

Hint:

Values are truncated after division, not rounded.

Vgen failed

The output closes if the generator over/under voltage shutdown alarm or voltage asymmetry shutdown alarm activates.

The output opens, if

- alarm is not active and
- **FAULT RESET** is pressed

fgen failed

Output closes if the generator over/under frequency shutdown alarm activates.

The output opens, if

- alarm is not active and
- **FAULT RESET** is pressed

Overload

Output closes if the generator overload shutdown alarm activates.
The output opens, if

- alarm is not active and
- **FAULT RESET** is pressed

Stop failed

Output closes when the engine has to be stopped, but speed or frequency or voltage or oil pressure is detected. This protection goes active 60s after stop command.

The output opens, if

- alarm is not active and
- **FAULT RESET** is pressed

Overspeed

Output closes if the gen-set over speed alarm activates.

The output opens, if

- alarm is not active and
- **FAULT RESET** is pressed

Underspeed

Output closes if the gen-set under speed alarm activates.

The output opens, if

- alarm is not active and
- **FAULT RESET** is pressed

Start failed

Output closes after the gen-set start-up fails.

The output opens, if

- alarm is not active and
- **FAULT RESET** is pressed

Overcurrent

Output closes if the generator
*IDMT over current or
current unbalance or
short current alarm activates.

The output opens, if

Alarm is not active and
FAULT RESET is pressed

Battery flat

Output closes when iL performs reset during start procedure (probably due to weak battery).

The output opens, if

- alarm is not active and
- **FAULT RESET** is pressed

V batt failed

Output closes when battery over/under voltage warning appears.

The output opens, if

- alarm is not active and
- **FAULT RESET** is pressed

Oil Press

Output closes if the oil pressure shutdown alarm activates.

The output opens, if

- alarm is not active and
- **FAULT RESET** is pressed

Oil Press Wrn

Output closes if the oil pressure warning alarm activates.
The output opens, if

- alarm is not active and
- **FAULT RESET** is pressed

Water Temp

Output closes if the water temperature shutdown alarm activates.
The output opens, if

- alarm is not active and
- **FAULT RESET** is pressed

Water Temp Wrn

Output closes if the water temperature warning alarm activates.
The output opens, if

- alarm is not active and
- **FAULT RESET** is pressed

FuelLevel

Output closes if the Fuel level shutdown alarm activates.

FuelLevelWrn

Output closes if the Fuel level warning alarm activates.

Common Wrn

Output closes when any warning alarm appears.
The output opens, if

- No warning alarm is active and
- **FAULT RESET** is pressed

Common Sd

Output closes when any shut-down alarm appears.
The output opens, if

- No sd alarm is active and
- **FAULT RESET** is pressed

Common FIs

Output closes when any sensor fail alarm appears.
The output opens, if

- No warning alarm is active and
- **FAULT RESET** is pressed

OFF mode

The output is closed, if OFF mode is selected.

MAN mode

The output is closed, if MAN mode is selected.

AUT mode

The output is closed, if AUT mode is selected.

ChrgAlternFail

Output closes if gen-set is running and D+ input not energized.
The output opens, if

- alarm is not active and
- **FAULT RESET** is pressed

Hint:

Treshold level for D+ input is 80% supply voltage.

ServiceTime

Output closes if the ServiceTime alarm activates.
The output opens, if

- alarm is not active and
- **FAULT RESET** is pressed

ECU CommOK

If the ECU is not communicating and all values from ECU show ##### the output is not active. If the ECU communicates the output is active.

ECU PwrRelay

The output closes at the beginning of prestart and opens if the engine shall be stopped.

ECU YellowLamp

The output copies warning information from ECU.

ECU RedLamp

The output copies shutdown information from ECU.

CtrlHeartBeat

Output signalizes watchdog reset. In a healthy state it blinks at 500ms : 500ms rate. When watchdog reset occurs, it stops blinking.

ECU CommError

The output is an inversion of binary output *ECU CommOK*, i.e. the output is closed when ECU is not communicating and all values from ECU show #####. Communication error causes stop of the engine.

BI1..6 – stat

*BI1..8IOM - stat

The outputs give an information about the assigned binary input.

In case the assigned binary input is configured to alarm type, then the output closes when the alarm activates. It opens if

- alarm is not active and
- **FAULT RESET** is pressed

In case the assigned binary input is configured to any control function, the output propagates the state of the input.

Timer1

Output activates when Timer1 is active. Simultaneously, gen-set is started when is in AUT mode.

Timer2

Output activates when Timer2 is active

GenParamsOK

The output is copy of generator status LED on iL front panel. The output is closed if genset is running and all genset electric values are in limits.

Glow plugs

The output closes prior to the engine start (*Prestart*) and opens when *Starting RPM* speed is reached. During repeated crank attempts the output is opened.

Supplying load

Closed when the generator current is $> 0,5\%$ of the CT ratio.

Exact formulas:

Output is closed when the current at least in one phase is for 1 sec over $CT\ ratio/200+2$

Output is opened when the current in all three phases is for 1 sec below $CT\ ratio/200+2$

Hint:

Values are truncated after division, not rounded.

Analog inputs

Three analog inputs are jumper configurable for resistive(default), voltage or current sensor.

It is possible to configure on each Analog input:

- Reading from IL Analog inputs or from Engine Control Unit via CAN bus (J1939)
- Sensor characteristics – from the list, or custom sensor curve
- Value dimension (e.g. psi - bars, °F - °C, % - l)
- Number of decimal points (0, 1, 2, ...).

Warning and shut-down limits are adjusted in **Engine protect** group.

The analog inputs are configurable. Use LiteEdit software to modify configuration. Default configuration is:

Oil press

Oil pressure analog input. Default VDO sensor in range 0 to 10.0 bars.

Water temp

Water temperature analog input. Default VDO sensor in range 0 to 100 °C.

Fuel level

Fuel level analog input. Default VDO sensor 0-180R = 0-100%

Hint:

For further information about analog inputs' configuration see [Analog inputs](#).

CAN J1939 interface

Following values can be received from Engine Control Unit via CAN bus instead of measuring on IL-NT terminals when J1939 interface is enabled.

Value	Value is received from	
	J1939 enabled	J1939 disabled
RPM	ECU	IL-NT – RPM terminals
Oil pressure	ECU or IL-NT AI1	IL-NT AI1 terminals
Water temperature	ECU or IL-NT AI2	IL-NT AI2 terminals
Fuel level	ECU or IL-NT AI3	IL-NT AI3 terminals
ECU State	ECU	
Fuel rate	ECU	
Manifold temp	ECU	
Boost pressure	ECU	
PercLoadAtCS	ECU	

Use LiteEdit 3.0 to enable/disable J1939 interface and to configure IL-NT analog inputs.

Hint:

RPM reading is automatically switched to pickup or generator voltage measuring (depends on **Basic setting**: *Gear teeth* value) if J1939 fails.

Setpoints

Password

EnterPassword

Password is a four-digit number. Password enables change of relevant protected set points Use \uparrow or \downarrow keys to set and **ENTER** key to enter the password. There are 3 levels of passwords. Knowledge of higher password lets you to change setpoint protected by lower password.

ChangePassword

Use \uparrow or \downarrow keys to set and **ENTER** key to change the password.

Hint:

At first the Password has to be entered before the new Password can be changed.

Basic settings

Gen-set name

User defined name, used for IntelliLite identification at remote phone or mobile connection. *Gen-set name* is max 14 characters long and have to be entered using LiteEdit software.

Nomin power [kW]

Nominal power of the generator

Step: 1kW

Range: 1 – 32000 kW

Nomin current [A]

It is current limit for generator *IDMT over current and short current protection and means maximal continuous generator current. See **Generator protections**: **Inom del*, *Ishort* setpoints.

Nominal current can be different from generator rated current value.

Step: 1 A

Range: 1 - 10000 A

CT Ratio [/5A]

Gen-set phases current transformers ratio.

Step: 1 A

Range: 1 – 5000 A / 5A

PT ratio [/1]

Gen-set potential transformers ratio.

Step: 0,1 V / V

Range: 0,1 – 500,0 V / V

Nomin voltage [V]

Nominal generator voltage (phase to neutral)

Step: 1V

Range: 80 – 20000 V

Nominal freq [Hz]

Nominal generator frequency (usually 50 or 60 Hz)

Step: 1Hz

Range: 45 – 65 Hz

Gear teeth [-]

Number of teeth on the engine gear for the pick-up.
Set to zero, if no pick-up is used. Engine speed is counted from the generator frequency.

Step: 1
Range: 0 – 500

Hint:

Generator frequency can be used only when generator voltage (min 5V) is present before reaching of the firing speed (*Starting RPM*) after start.

Nominal RPM [RPM]

Nominal engine speed.
Step: 1RPM
Range: 100 – 4000 RPM

ControllerMode [OFF, MAN, AUT]

Equivalent to Controller mode changes by **MODE→** or **←MODE** buttons.

Hint:

Controller Mode change can be separately password protected.

FltResGoToMAN [ENABLED/DISABLED]

DISABLED: Controller stays in AUT mode after Fault reset .
ENABLED: Automatic switch from AUT (or TEST) to MAN mode after Fault reset to avoid automatic engine start. This function is active for Shut down protection only.

DispBaklightTO [min]

Timeout after which the display backlight is switched off.
Step: 1 min
Range: 0 – 60 min
Default value: 0 ... means that the display lights all the time

Contr. addr (1 .. 32) [-]

Controller identification number. It is possible to set controller address different from the default value (1) so that more IL controllers can be interconnected (via RS485) and accessed e.g. from Modbus terminal.

Hint:

When opening connection to the controller it's address has to correspond with the setting in PC tool. From LiteEdit it is only possible to connect to controllers with address 1.

***RS232 mode** [STANDARD/MODBUS/CumminsMB]

Communication protocol switch.
Standard: LiteEdit communication protocol.
Modbus: Modbus protocol.
CumminsMB: Protocol for communication with Cummins engines via Modbus.

Hint:

For detail description see chapter Modbus protocol.

Engine params

Starting RPM [%]

“Firing” speed when IL controller stops cranking (starter goes OFF).

Step: 1% of nominal RPM
Range: 5 – 50 %

Starting POil [Bar]

When reached controller stops cranking (starter goes OFF).

Step: 0,1 bar
 Range: 0,0 – 10,0

Hint:

There are three conditions for stop cranking: Starting RPM, StartingPOil and D+ (when enabled). Starter goes off when any of these conditions is void.

Prestart time [s]

Time of closing of the PRE-START output prior to the engine start.
 Set to zero if you want to leave the output PRE-START open.

Step: 1s
 Range: 0 – 600 s

MaxCrank time [s]

Maximum time limit of cranking.

Step: 1s
 Range: 1 – 60 s

CrnkFail pause [s]

Pause between crank attempts.

Step: 1s
 Range: 5 – 60 s

Crank attemps [-]

Max number of crank attempts.

Step: 1
 Range: 1 – 10

Idle time [s]

Idle time delay starts when RPM exceeds *Start RPM* . Start fail is detected when during Idle state RPM decreases below 2.

During the *Idle time* timer running the binary output IDLE/NOMINAL is opened, when it elapses the IDLE/NOMINAL output closes. Binary output IDLE/NOMINAL opens during Cooling period again.

Step: 1 s
 Range: 0 – 600 s

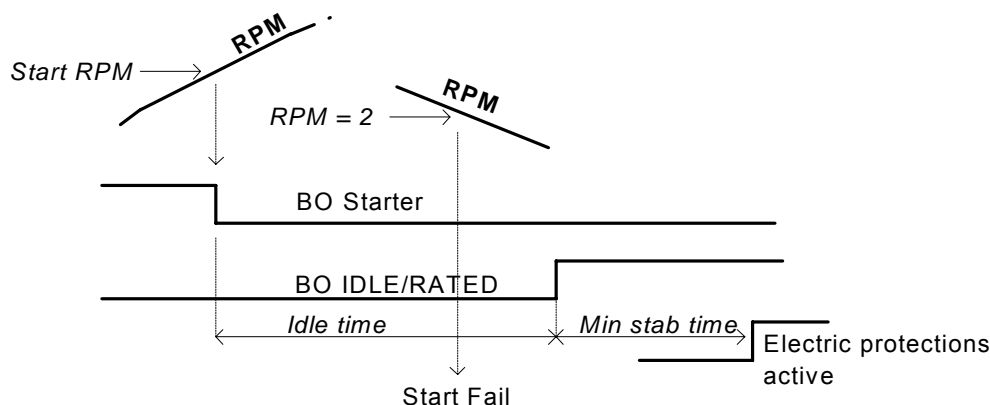

Hint:

If the IDLE function not supported on the governor, set the *Idle time* nevertheless to minimum 5s to avoid *Underspeed* possibly caused by instability of the engine short after start.

Min stab time [s]

Minimum time after reaching of defined level of RPM to the closing GCB.

Step: 1s
Range: 1 – 300 (Max stab time) s

Max stab time [s]

Maximum time after start to get proper voltage level of the generator.

Step: 1s
Range: 1 (Min stab time) – 300 s

Hint:

When generator voltage within *Max stab time* does not reach defined limits (Generator protection group), an alarm occurs and the genset will shut down

Cooling speed [NOMINAL / IDLE]

Selects the function of the Binary output IDLE/NOMINAL during engine Cooling state.

NOMINAL : Cooling is executed at Nominal speed and generator protections are active.
IDLE: Cooling is executed at Idle speed and generator protections are switched off.

Hint:

Binary output IDLE/NOMINAL must be configured and connected to speed governor. Engine Idle speed must be adjusted on speed governor.

Cooling time [s]

Runtime of the unloaded gen-set to cool the engine before stop.

Step: 1s
Range: 0 – 3600 s

Stop time [s]

Under normal conditions the engine must certainly stop within this period. The period starts by issuing stop command.

Step: 1s
Range: 0 – 240 s

Hint:

Stop of engine is detected when all following conditions are met: RPM < 2, Oil pressure < *StartingPOil* Generator voltage < 10 VAC and D+ input isn't active.

Stop fail is detected when there is difference between those conditions, e.g RPM < 2 and Generator voltage > 10V.

AfterCool time [s]

Runtime of engine after cooling pump. Binary output *Cooling pump* is closed when the engine starts and opens *AfterCool time* delayed after gen-set stops.

Step: 1s
Range: 0 – 3600s

Fuel solenoid [DIESEL / GAS]

Determines behavior of the Binary output FUEL SOLENOID.

DIESEL: Output closes 1 sec before Binary output STARTER.

The output opens if Emergency stop comes or Cooled gen-set is stopped and in pause between repeated starts.

GAS: Output closes together with Binary output IGNITION if RPM is over the *30 RPM (fix value)*. Output opens after stop command or in pause between repeated start.

D+ function [ENABLED/CHRGFAIL/DISABLED]

ENABLED: The D+ terminal is used for both functions – “running engine” detection and charge fail detection.

CHRGFAIL: The D+ terminal is used for charge fail detection only

DISABLED: The D+ terminal is not used.

Hint:

The magnetization current is provided independently on this setpoint value.
The D+ charge fail protection becomes active after **Engine params: Idle time** reaches zero.

ECU FreqSelect [PRIMARY/SECONDARY/DEFAULT]

This setpoint should be used only for Volvo and Scania engines.

Volvo – “Volvo Aux” is selected in ECU configuration:

Primary or secondary engine speed is set by *Frequency select* bits in **VP Status** frame.

Scania – “Scania S6 Singlespeed” is selected in ECU configuration:

Nominal engine speed is chosen by *Nominal speed switch 1* and *2* from **DLN1** frame when the engine is running on nominal speed, i.e. binary output *Idle/Nominal* is active. When the output is not active (engine is running on Idle speed), the setpoint *ECU FreqSelect* is not taken into account.

Frequency change for Volvo Penta engines with EMS2

This description refers to the Volvo Penta Application bulletin 30-0-003.

The procedure for changing engine speed on the D9 and D16 engines is different from the D12 engine.

There is no system reset on the EMS2 unit; therefore the procedure is changed.

Procedure if ECU not energized:

1. Switch the IL controller to MAN mode.
2. Power up the ECU.
3. Change the setpoint *ECU FreqSelect* and confirm it by pressing Enter
4. Press the Stop button on the IL controller.

The whole procedure (step 2 to 4) must not exceed **10 seconds**.

Procedure with ECU powered on:

1. Switch the IL controller to MAN mode.
2. Press the Stop button on the IL controller.
3. Change the setpoint *ECU FreqSelect* and confirm it by pressing Enter
4. Press the Stop button on the IL controller.

The whole procedure (step 2 to 4) must not exceed **10 seconds**.

ECU SpeedAdj [%]

Enables to adjust engine speed in ECU via CAN bus. Nominal speed corresponds to 50%.

This setpoint should be used only for Volvo Penta and Scania engines. It has no effect on other engine brands.

Step: 1%

Range: 0 – 100%

Engine protect

Eng prot del [s]

During the start of the gen-set, some engine protections have to be blocked (e.g. Oil pressure).

The protections are unblocked after the *Protection del* time. The time starts after reaching *Start RPM*.

Step: 1s

Range: 0 – 300 s

Horn timeout [s]

Max time limit of horn sounding. Set to zero if you want to leave the output HORN open. Horn timeout starts again from the beginning if a new alarm appears before previous Horn timeout has elapsed.

Step: 1s

Range: 0 – 600 s

Overspeed [%]

Threshold for over speed protection
Step: 1% of nominal RPM
Range: 100 – 150%

AnlInp1 level1 [Bar]

Warning threshold level for ANALOG INPUT 1
Step: 0,1 bar
Range: -10 – 1000

AnlInp1 level2 [Bar]

Shutdown threshold level for ANALOG INPUT 1
Step: 0,1 bar
Range: -10 – 1000

AnlInp1 del [s]

Delay for ANALOG INPUT 1
Step: 1 s
Range: 0 – 180 s

AnlInp2 level1 []

Warning threshold level for ANALOG INPUT 2
Step: 1 °C
Range: -100 – 10000

AnlInp2 level2 []

Shutdown threshold level for ANALOG INPUT 2
Step: 1 °C
Range: -100 – 10000

AnlInp2 del [s]

Delay for ANALOG INPUT 2 alarm.
Step: 1 s
Range: 0 – 180 s

AnlInp3 level1 []

Warning threshold level for ANALOG INPUT 3
Step: 1 %
Range: -100 – 10000

AnlInp3 level2 []

Shutdown threshold level for ANALOG INPUT 3
Step: 1 %
Range: -100 – 10000

AnlInp3 del [s]

Delay for ANALOG INPUT 3
Step: 1 s
Range: 0 – 180 s

Batt overvolt [V]

Warning threshold for high battery voltage.
Step: 0,1 V
Range: 8(Batt undervolt)– 40 V

Batt undervolt [V]

Warning threshold for low battery voltage.

Step: 0,1 V

Range: 8V – 40 (Batt overvolt)

Batt volt del [s]

Delay for low battery voltage alarm.

Step: 1s

Range: 0 – 600 s

NextServTime [h]

Counts down when engine running. If reaches zero, an alarm appears.

Step: 1h

Range: 0 – 65535h

Gener protect

Hint:

All electric protections when activated result in shutdown.

Overload [%]

Threshold for generator overload (in % of Nominal power)

Step: 1% of Nominal power

Range: 0 – 200%

Overload del [s]

Delay for generator overload alarm.

Step: 0.1s

Range: 0 – 600.0 s

Ishort [%]

Shutdown occurs when short circuit limit *Ishort* limit is reached.

Step: 1 % of *Nominal current*

Range: 100 - 500 %

Ishort del [s]

Delay for generator shorcurrent alarm.

Step: 0.01s

Range: 0.00 – 10.00 s

***2Inom del [s]**

IDMT curve shape selection. *2Inom del* is Reaction time of IDMT protection for 200% overcurrent
 $I_{gen} = 2 * \text{Nominal current}$.

Step: 0,1 s

Range: 0,1 - 60,0 s

IDMT is “very inverse” generator over current protection. Reaction time is not constant but depends on generator over current level according following formula.

$$\text{Reaction time} = \frac{2Inom\ del * Nomin\ current}{I_{gen} - Nomin\ current}$$

Hint:

Reaction time is limited up to 900 sec = 15 minutes. IDMT protection is not active for Reaction time values longer than 15 minutes.

I_{gen} is maximal value of all measured phases of generator current.

EXAMPLE of Reaction time for different over current levels. Values in column 200% are $2I_{nom del}$.

	Overcurrent			
	200 % = $2I_{nom del}$	≤ 100 %	101 %	110 %
Reaction time	0,2 s	No action	20 s	2 s
	2 s	No action	200 s	20 s
	20 s	No action	No action (time > 900 s)	200 s

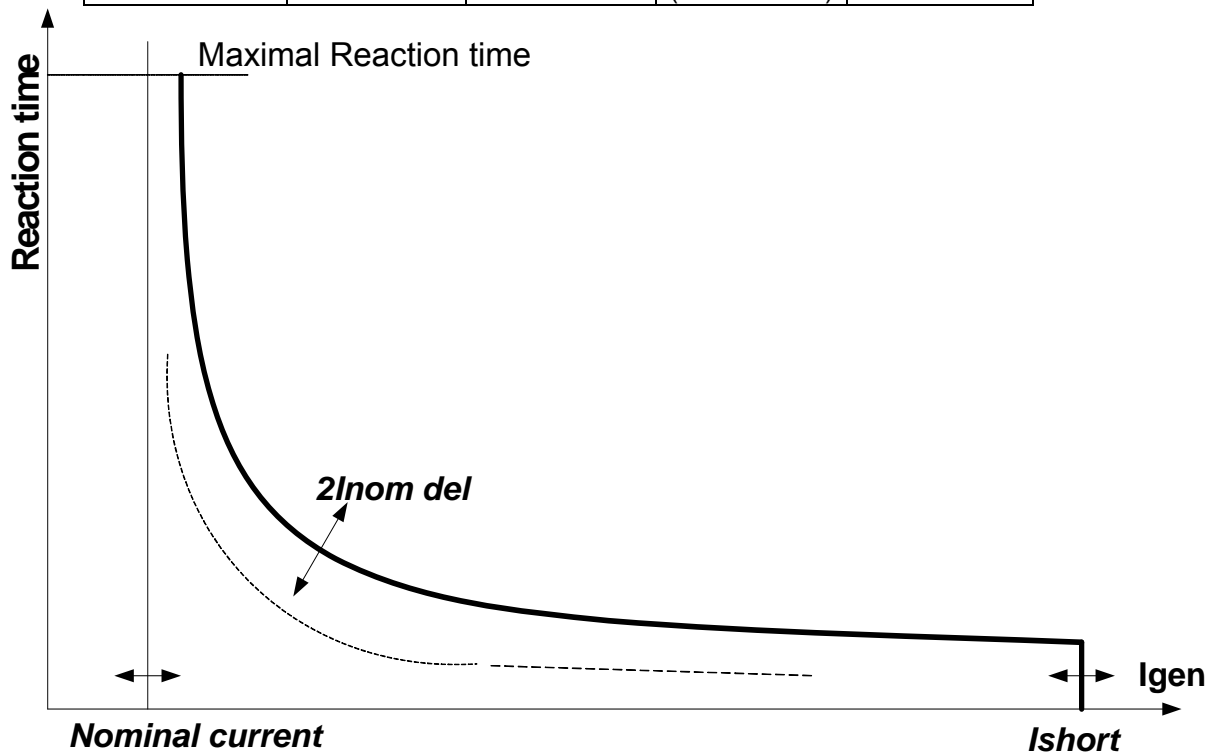

Curr unbal [%]

Threshold for generator current asymmetric (unbalance).

Step: 1% of Nominal current

Range: 1 – 200% of Nominal current

Curr unbal del [s]

Delay for generator current unbalance

Step: 0.1 s

Range: 0.0 – 600.0 s

Gen >V Sd [%]

Threshold for generator overvoltage. All three phases are checked. Maximum out of three is used.

Step: 1% of Nominal voltage

Range: 0(Gen <V Sd) – 200%

Gen <V Sd [%]

Threshold for generator undervoltage. All three phases are checked. Minimum out of three is used.

Step: 1% of Nominal voltage
Range: 0% – 200 (Gen >V Sd)%

Gen V del [s]

Delay for generator undervoltage and overvoltage alarm

Step: 0.1s
Range: 0.0 – 600.0 s

Volt unbal [%]

Threshold for generator voltage unbalance alarm.

Step: 1% of Nominal voltage
Range: 0 – 200% of Nominal voltage

Volt unbal del [s]

Delay for generator voltage unbalance alarm.

Step: 0.1s
Range: 0.0 – 600.0 s

Gen >f [%]

Threshold for generator phase L3 overfrequency.

Step: 0.1% of Nominal frequency
Range: 0 (Gen <f) – 200.0% of Nominal frequency

Gen <f [%]

Threshold for generator phase L3 underfrequency.

Step: 0.1% of Nominal frequency
Range: 0.0 – 200 (Gen >f) % of Nominal frequency

Gen f del [s]

Delay for generator underfrequency and overfrequency alarm.

Step: 0.1s
Range: 0.0 – 600.0 s

Date/Time

Time stamp per [min]

Time interval for periodic history records.

Step: 1 min
Range: 0 – 200min

#SummerTimeMod [DISABLED / WINTER / SUMMER,WINTER-S, SUMMER-S]

DISABLED: Automatic switching between summer and wintertime is disabled.

WINTER (SUMMER) : Automatic switching between summer and wintertime is enabled and it is set to winter (summer) season.

WINTER-S (SUMMER-S) : Modification for southern hemisphere.

#Time [HHMMSS]

Actual real time

#Date [DDMMYYYY]

Actual date.

Timer1..2 repeat

[NONE/MONDAY/TUESDAY/WEDNESDAY/THURSDAY/WEDNESDAY/FRIDAY/SATURDAY/SUNDAY/MON-FRI/MON-SAT/MON-SUN/SAT-SUN]

Defines TIMER1 activation. Binary output TIMER1 is internally linked with Rem Start/Stop binary input. Refer to binary inputs for details.

NONE: Timer function is disabled
 MONDAY, TUESDAY, WEDNESDAY, THURSDAY, WEDNESDAY, FRIDAY, SATURDAY, SUNDAY:
 Timer is activated on daily basis.
 MON-FRI, MON-SAT, SAT-SUN:
 Timer is activated on selected day interval.

Timer1..2 ON time

Day time when Timer output activates.

Timer1..2Duration

Duration of Timer output is active.

Step: 1 min
 Range: 1 – 1440 s

Sensor spec

Calibr AI1,AI2,AI3 [...]

Calibrating constant to adjust the measured value of IL analog inputs. Physical dimension of calibrating constant is corresponding to Analog input.

Step: 1
 Range: -1000 – +1000

Hint:

Calibration constants have to be adjusted when measured value is near the alarm level. User curves A, B, C can be defined by LiteEdit software.

CalibrAIInIOM 1..4 [...]

Calibrating constant to adjust the measured value of IOM/PTM analog inputs. Physical dimension of calibrating constant is corresponding to Analog input.

Step: 1
 Range: -1000 – +1000

*IOM/PTM module

AnInIOM1..4 lev1 []

The level for IOM ANALOG INPUT 1..4 alarm detection.

Step: 1
 Range: -100 - +10000

AnInIOM1..4 lev2 []

The level for IOM ANALOG INPUT 1..4 alarm detection.

Step: 1
 Range: -100 - +10000

AnInIOM1..4 del [s]

Delay for IOM ANALOG INPUT 1..4 alarm.

Step: 1 s
 Range: 0 - 180 s

Hint:

IG-IOM/IGS-PTM analog inputs protection alarms can be configured following way

Configuration	Protection
Under	Protection is activated only when measured value is under measured level.
Over	Protection is activated only when measured value is over measured level.
Under+fls	Level 2 protection is activated by sensor fail as well.
Over+fls	Level 2 protection is activated by sensor fail as well.

*ECU-controlled engine support

There exists only one firmware branch for both standard and electronic controlled (monitored) engines.

Presence of the ECU on the CAN bus/RS232 is configured via LiteEdit like other peripherals (IG-IOM,



IGL-RA15). Pressing the  button in Configuration window of LiteEdit (version 2.0 and higher), opens ECU dialog window where the appropriate engine/ECU type should be selected. There are three groups of engine/ECU types:

Type selection	Supported engine/ECU
Caterpillar EMCP3.1	
Caterpillar J1939	
Cummins CM570	
Cummins MODBUS	Cummins engines with Modbus communication support
DDC DDEC IV	Detroit Diesel DDEC IV, V
Deutz EMR2	
Iveco	
Jenbacher Diane	
John Deere	
Perkins ECM	
Scania S6 Singlespeed	Scania engines with S6 unit
Scania S6 Singlespeed newSW	Scania engines with S6 unit
SISU EEM3 gen-set	
Standard J1939 engine	All other engine brands with J1939 support
Volvo Aux	Volvo Penta engines with EMSII, EDCIII units

ECU list – Gensets.esl, version 3.4

Hint:

Import latest ECU list – Gensets.iwe for up to date engine ECU specification.

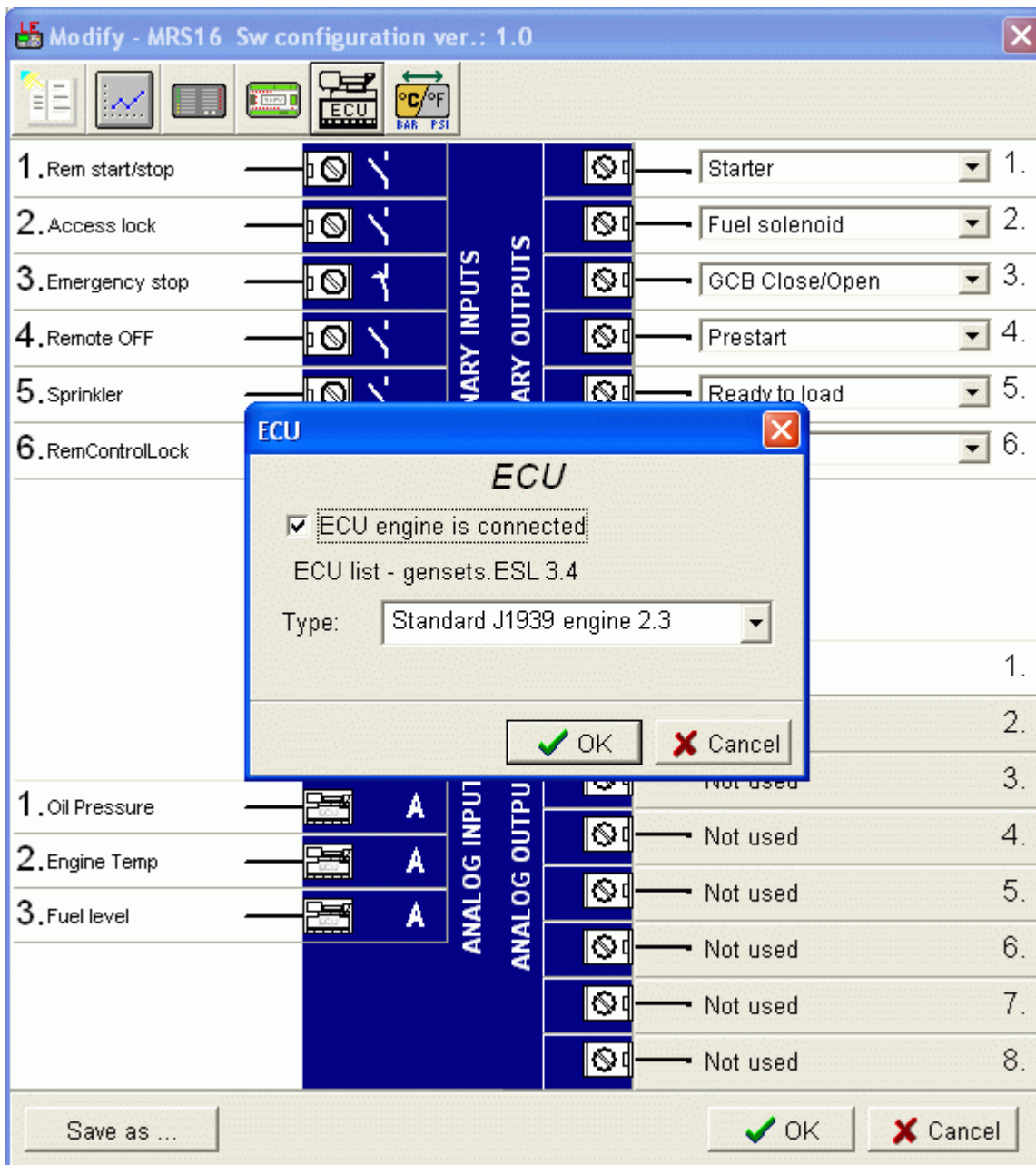

If the connected engine is Cummins communicating via RS232, it is necessary to set the setpoint **Basic settings:RS232 mode = CUMMINSMB**.

Loss of communication causes shutdown of the running engine. On the contrary, the ECU can be switched off at quiescent engine, that means not-communicating ECU is in that moment normal situation. All values from ECU shall show #####, but no alarm is displayed. The output *ECU CommOK* follows the real situation, that means it is not active anytime when the ECU does not communicate.

The output *ECU PwrRelay* closes at the beginning of prestart and opens if the engine shall be stopped.

The engine is started via standard contact output or via CAN bus (for Volvo and Scania engines). For other engines J1939 is used for monitoring only.

Values read from ECU

Standard J1939 engines and Scania

When “Standard J1939 engines” and “Scania S6” options are selected, following values are read from standard J1939 frames:

- 5.2.1.9 Engine speed (frame 5.3.7 EEC1)
- 5.2.5.28 Engine oil pressure (frame 5.3.29 Engine Fluid Level/Pressure)
- 5.2.5.5 Engine coolant temperature (frame 5.3.28 Engine Temperature)
- 5.2.5.61 Total engine hours (frame 5.3.19 Engine Hours, Revolutions)
- 5.2.1.7 Percent load at current speed (frame 5.3.6 EEC2)
- 5.2.5.63 Fuel rate (frame 5.3.32 Fuel Economy)
- 5.2.5.36 Boost pressure (frame 5.3.36 Inlet/Exhaust Conditions)
- 5.2.5.4 Intake manifold 1 temperature (frame 5.3.36 Inlet/Exhaust Conditions)

Cummins MODBUS

When “Cummins-Modbus” option is selected, following values are read from Modbus Register Data (for QSK15, QSK45, QSK60):

- Engine Speed (Register Address:30001)
- Oil Pressure (Register Address:30003)
- Coolant Temperature (Register Address:30002)
- Engine Running Time (Register Address:30008-30009)
- Fuel Consumption Rate (Register Address:30018)
- Intake Manifold Absolute Pressure (Register Address:30530 (QSK45, QSK60 only))
- Intake Manifold Temperature (Register Address:30531 (QSK45, QSK60 only))

Diagnostic messages read from ECU

Diagnostic messages are read and displayed in extra [ECU Alarm list](#). For Standard J1939 SPN (Suspect Parameter Number), FMI (Failure Mode Identifier) and OC (Occurrence Counter) are shown together with verbal description if available.

One SPN (Suspect Parameter Number) / FMI (Failure Mode Identify) couple describes one fail information. If FMI is equal to 0 or 1, WRN is displayed in the ECU Alarm list. For any other FMI values, FLS is displayed.

Detail SPM/FMI code specification see in:

- SAE Truck and Bus Control and Communications Network Standards Manual, SAE HS-1939 Publication
- Or refer to corresponding engine manufacturer’s ECU error codes list.

Following messages are displayed with the description:

- SPN:100 EngOil Press
- SPN:102 Boost Press
- SPN:105 Intake Temp
- SPN:110 EngCool Temp
- SPN:175 EngOil Temp
- SPN:629 Controller#1
- SPN:636 PositionSensor
- SPN:637 TimingSensor
- SPN:651 InjectorCyl#1
- SPN:652 InjectorCyl#2
- SPN:653 InjectorCyl#3
- SPN:654 InjectorCyl#4
- SPN:655 InjectorCyl#5
- SPN:656 InjectorCyl#6
- SPN:677 EngStartRelay
- SPN:1485 ECU MainRelay

Hint:

InteliLite controller doesn’t support J1587 diagnostic line on Volvo engines. This can cause in some cases a J1939 alarm message FC:000608 due to missing J1587 bus. Contact your Volvo distributor to update ECU firmware.

For Scania Fault codes (FC) are displayed. Following messages are available for particular groups of Fault codes:

- FC:1000-1001 Overspeed
- FC:1100-1107 EngSpdSensor1
- FC:1200-1207 EngSpdSensor2
- FC:2000-2002 WtrTempSensor
- FC:2100-2102 ChrgAirTmpSens
- FC:2200-2202 ChrgAirPrsSens
- FC:2400-2403 OilPressSensor
- FC:2600-2601 SensorSupply1
- FC:2700-2701 SensorSupply2
- FC:2800-2802 ExtrAnalogInp
- FC:3200-3205 BatteryVoltage
- FC:4300-4303 HW Watchdog
- FC:6200-6201 FanActuator
- FC:6400-6401 WasteGateAct
- FC:6600-6601 StarterActuatr
- FC:6A00-6A01 ExhaustBrkAct
- FC:B000-B001 OilPressProt
- FC:B100-B101 CoolantLevProt
- FC:B200 OverheatCoolWt
- FC:B300 EmergencyStop
- FC:C000-C006 PDEInjctorCyl1
- FC:C100-C106 PDEInjctorCyl2
- FC:C200-C206 PDEInjctorCyl3
- FC:C300-C306 PDEInjctorCyl4
- FC:C400-C406 PDEInjctorCyl5
- FC:C500-C506 PDEInjctorCyl6
- FC:C600-C606 PDEInjctorCyl7
- FC:C700-C706 PDEInjctorCyl8
- FC:E200 OverheatProt
- FC:E600 CoordEmergStop

Analog inputs

Reading of mentioned values from ECU enables to use analog inputs of the unit for other purposes, e.g. measuring, displaying and alarm activation related to various quantities. The configuration thus allows to use three analog inputs on the central unit and four analog inputs on IG-IOM/IGS-PTM module if connected.

If the engine without ECU is controlled by IntelliLite, the first analog input is permanently configured to Oil pressure, other analog inputs remain freely configurable.

Connection description

The following diagrams show how to connect the engine control unit to the IntelliLite controller:

Engines with J1939 support started via CAN bus

VOLVO PENTA engines (EMS II, EDC III units)

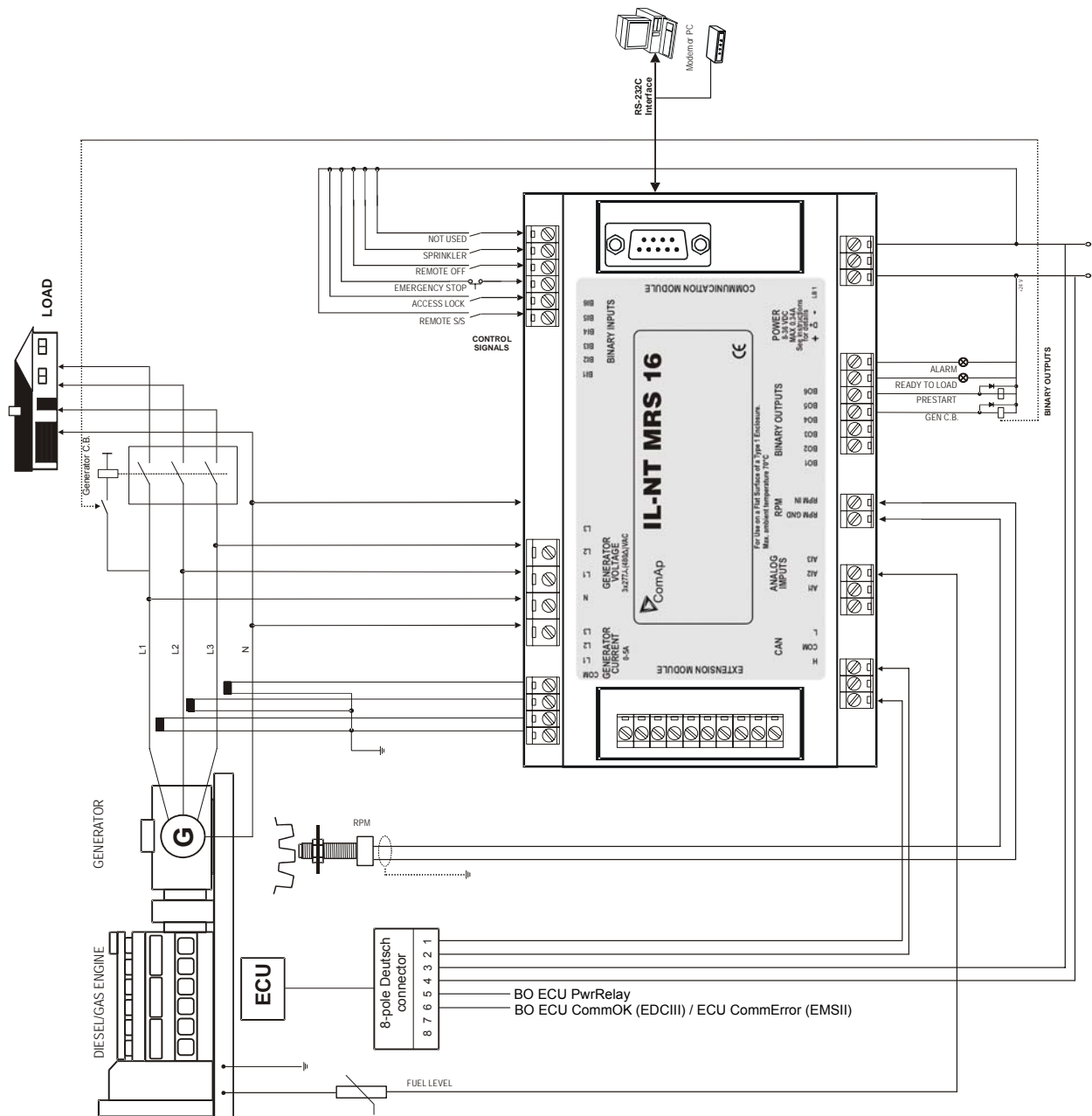

SCANIA S6

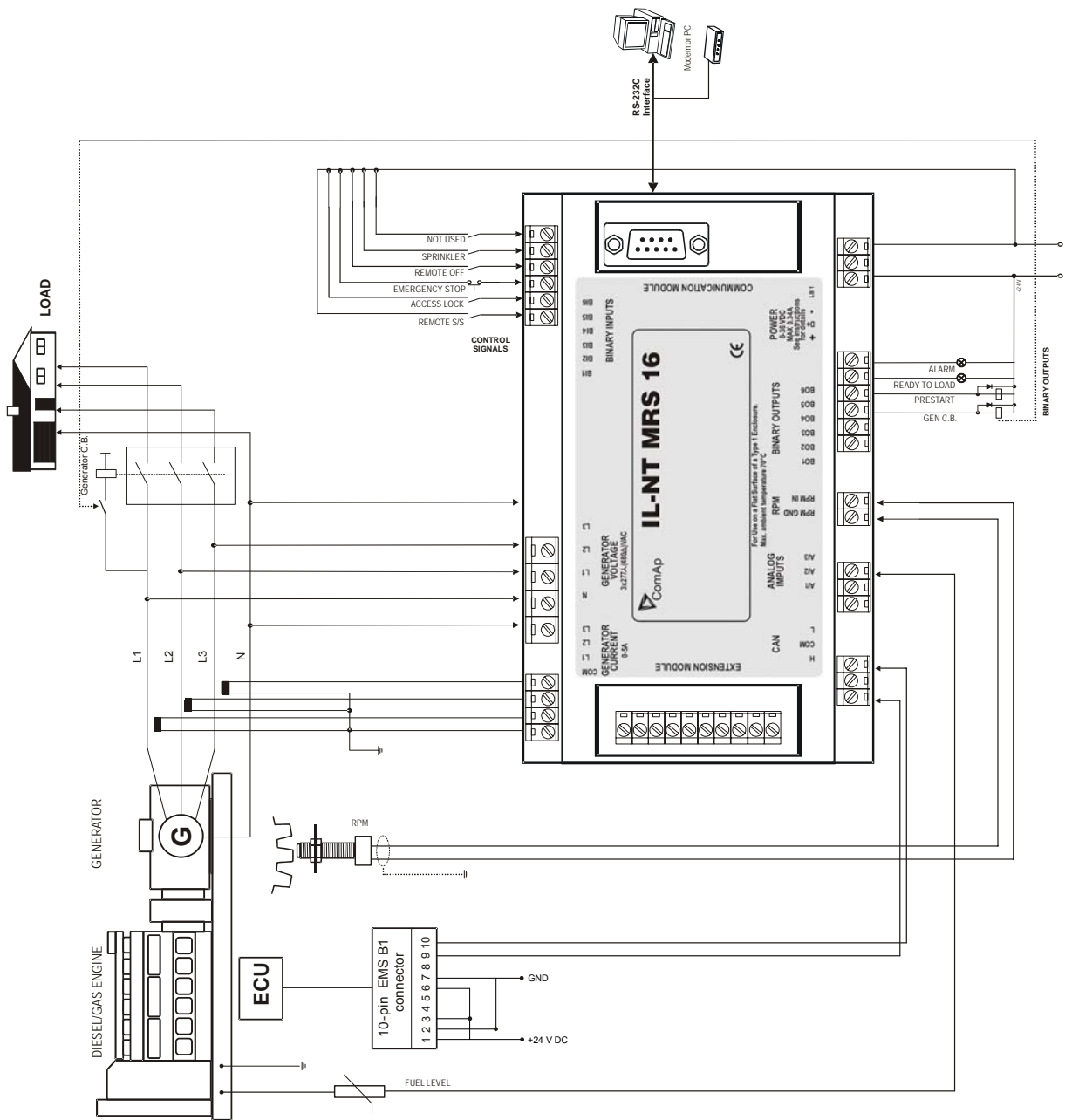

Engines not started via CAN bus

PERKINS 2800 series

IL-NT binary output description	Perkins Customer interface connector
Start output	connects directly to engine starter solenoid
Fuel output	1,10,15,33,34 powers up ECU and enables the injectors

IL-NT CAN description	Perkins Customer interface connector
CAN bus common	Screen for the J1939 cable.
CAN bus H	31
CAN bus L	32

JOHN DEERE

IL-NT binary output description	John Deere 21 pin Deutsch connector
Start output	D
Fuel output	G (switched ECU power),J (ignition)

IL-NT CAN description	John Deere 21 pin Deutsch connector
CAN bus common	Screen for the J1939 cable.
CAN bus H	V
CAN bus L	U

CUMMINS ISB/ISBE

IL-NT binary output description	Cummins ISB OEM Harness connector B
Start output	connects directly to engine starter solenoid
Fuel output	39

IL-NT CAN description	Cummins ISB 9 pin Deutsch connector
CAN bus common	SAE J1939 shield - screen for J1939 cable.
CAN bus H	SAE J1939 signal
CAN bus L	SAE J1939 return

Cummins engines with MODBUS communication

IntelliLite set up (available from version 2.0):

Basic settings: RS232 mode = CUMMINS MB

Software configuration: ECU → ECU engine is connected → Type: Cummins MODBUS

RS232/RS485 converter (see following diagram) set up:

Data format settings (SW1) 11 bits (1 start bit, 8 data bits, 2 stop bits)

Baud rate settings (SW2) 9600 bps

(more info available on http://www.advantech.com/products/Model_Detail.asp?model_id=1-D6FLH)

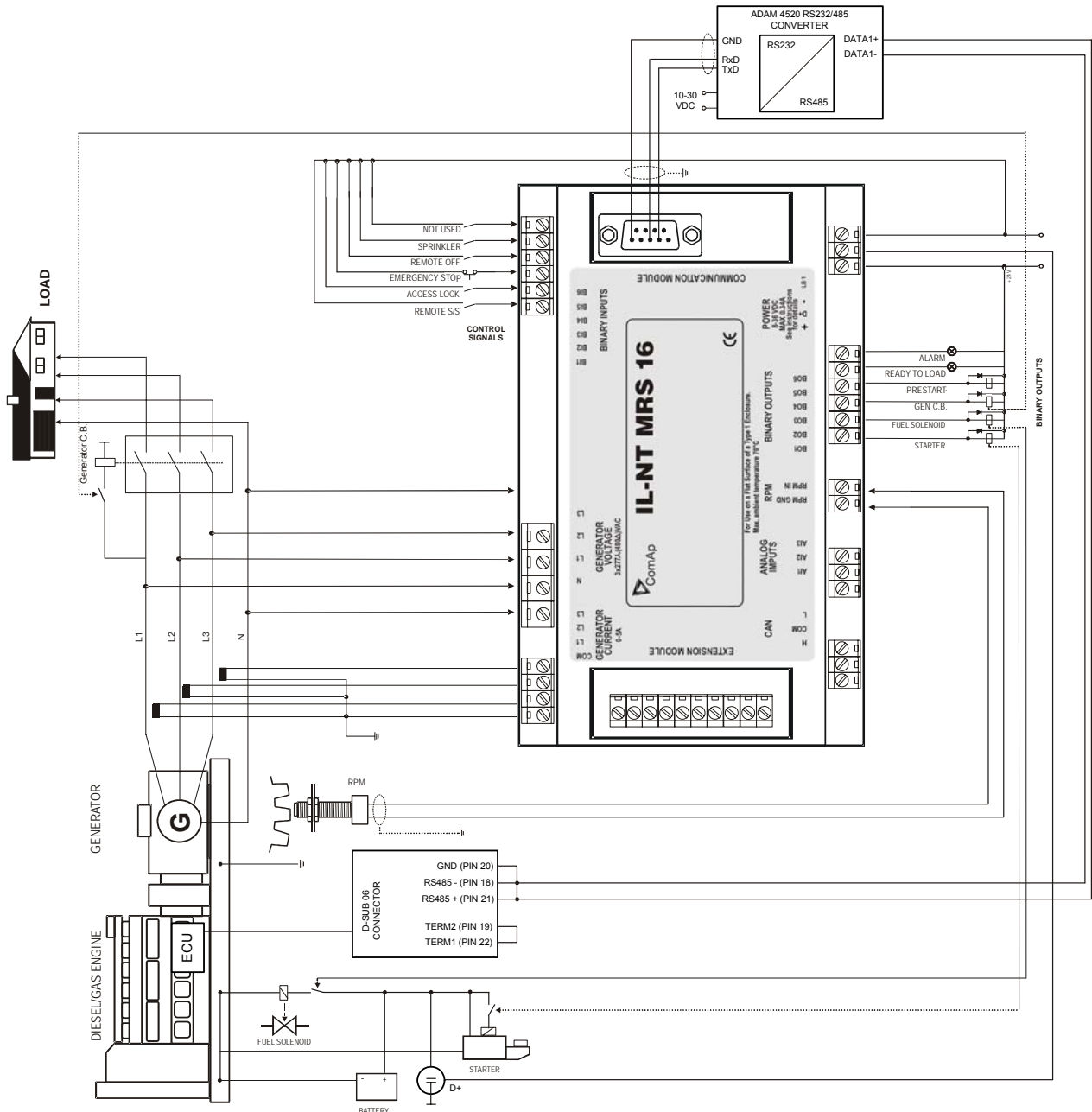

Sensor specification

Background of the sensor calibration

To correct measuring error of each analog input (pressure, temperature, level) calibrating constants within 10 % of measure range should be set. Three (seven) calibrating constants are set in physical units - bar, °C, % . From these constants are counted equivalent calibrating resistance which are internally (in software) add to sensor resistance.

At the moment of calibration (ENTER pressing) is calculated (and in memory saved) calibrating resistance (in Ω). This value is added to measured sensor resistance before calculation of the AI1 (AI2 or AI3) value.

Example: iL-NT display Temperature 70 °C and real value is 73 °C.

After setting *Calibr AI1* to +3 °C (and pressing ENTER) IntelliLite calculates corresponding resistance (e.g. 5 Ω) and saves this value into the memory. The resistance is then added to all calculations (e.g. instead of 70°C -> 73°C, or e.g. instead of 5°C -> 6°C).

Hint:

The calibration must be done at the operational point of the analog input (e.g. 80°C, 4.0Bar etc..)

Default sensor settings

Analog input 1: 6 points VDO characteristic, pressure measuring in bar

Analog input 2: 10 points VDO characteristic, temperature measuring in °C

Analog input 3: 2 points VDO fuel level sensor, 0% = 10 Ω , 100% = 180 Ω

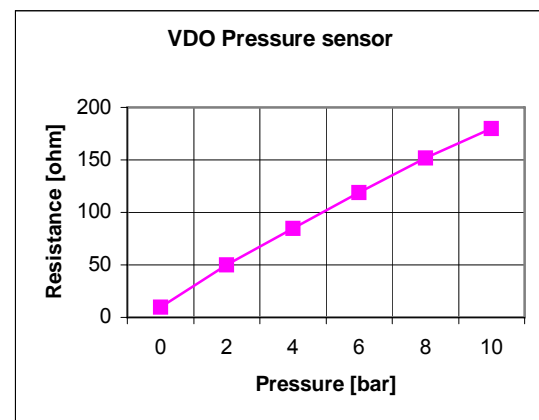
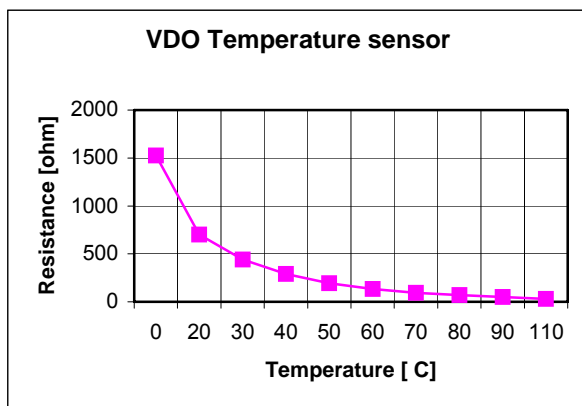

Temperature °C	Pt 1000 ohm	Ni 1000 ohm
-20	922	893
-10	961	946
0	1000	1000
30	1117	1171
60	1232	1353
80	1309	1483
90	1347	1549
100	1385	1618
110	1423	1688
120	1461	1760

Hint:

When measured value is 6% out of range the Sensor fail FLS is detected.

Operator interface

Pushbuttons and LEDs, MRS10/11/15/16

Pushbuttons

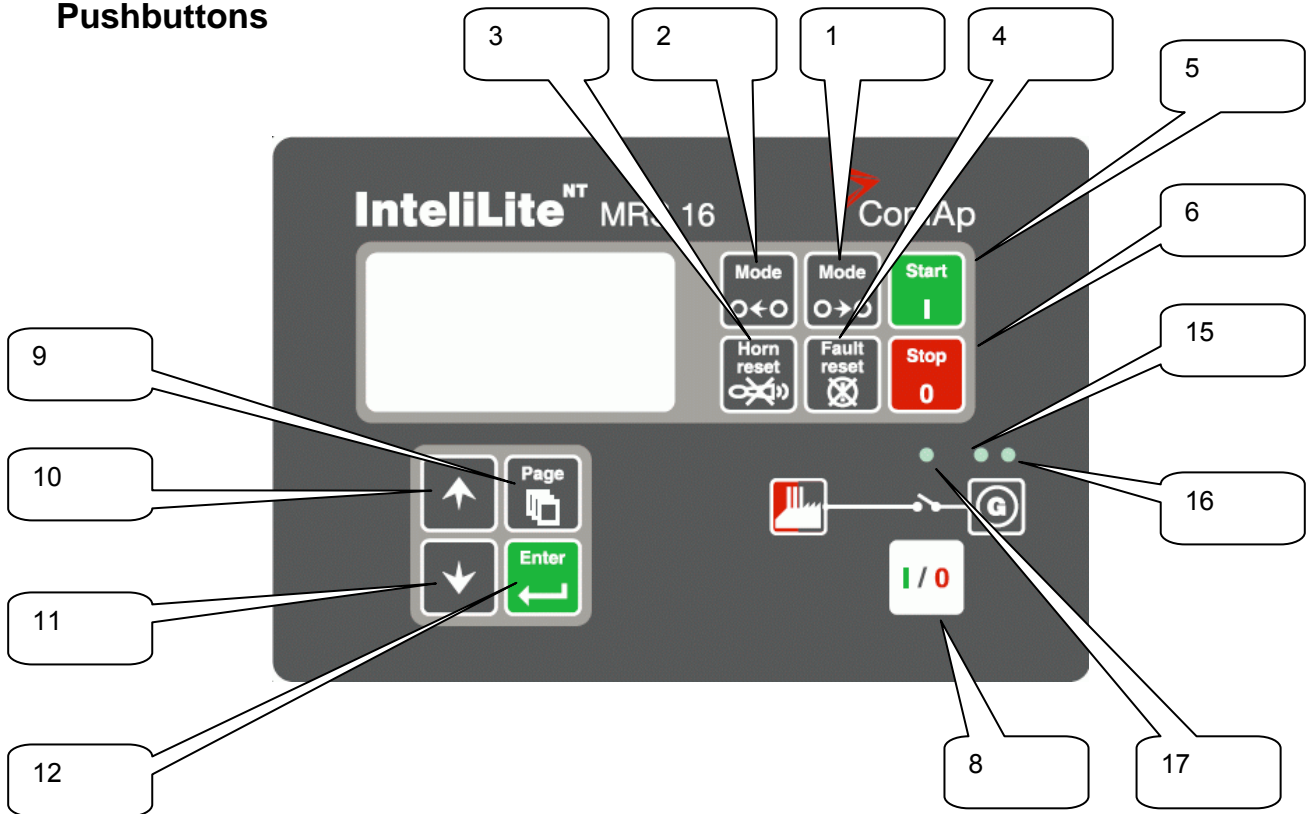

1. **MODE→** Cyclic forward selection the gen-set operation mode (OFF -> MAN -> AUT)
2. **←MODE** Cyclic backward selection the gen-set operation mode (AUT -> MAN ->OFF)
3. **HORN RESET** Deactivates the HORN
4. **FAULT RESET** Acknowledges faults and alarms
5. **START** Start of the gen-set
6. **STOP** Stop of the gen-set
- 7.
8. **GCB ON/OFF** ^Manual open/close of the Generator circuit breaker
9. **PAGE** Cyclic selection of the display mode(MEASUREMENT->ADJUSTEMENT)
10. **↑** Select the set point, select the screen or increase set point value
11. **↓** Select the set point, select the screen or decrease set point value
12. **ENTER** Confirm set point value

LEDs

- 13.
- 14.
15. GEN VOLTAGE PRESENT: GREEN LED is on, if gen. voltage is present and within limits
16. GEN-SET FAILURE: RED LED starts flashing when gen-set failure occurs. After **FAULT RESET** button is pressed, goes to steady light (if an alarm is still active) or is off (if no alarm is active)
17. ^GCB ON: GREEN LED is on, if GCB is closed. Driven by GCB CLOSE/OPEN output.

How to select the gen-set mode ?

Use **MODE→** or **←MODE** to select requested gen-set operation mode (OFF – MAN – AUT)

^When to use button **GCB ON/OFF**?

In AUT mode this button is disabled.

In MAN mode is enabled, but before closing of a circuit breaker, voltage must be within limits.

Display menus

There are 2 display menus available: MEASUREMENT and ADJUSTMENT

Each menu consists of several screens. Press repeatedly **PAGE** button to select requested menu.

How to view measured data?

1. Use repeatedly **PAGE** button to select the MEASUREMENT menu.
2. Use **↑** and **↓** to select the screen with requested data.

How to view and edit set points?

1. Use repeatedly **PAGE** button to select the ADJUSTMENT menu.
2. Use **↑** or **↓** to select requested set points group.
3. Press **ENTER** to confirm.
4. Use **↑** or **↓** to select requested set point.
5. Set points marked “*” are password protected.
6. Press **ENTER** to edit.
7. Use **↑** or **↓** to modify the set point. When **↑** or **↓** is pressed for 2 sec, auto repeat function is activated.
8. Press **ENTER** to confirm or **PAGE** to leave without change.
9. Press **PAGE** to leave selected set points group.

How to change the display contrast ?

Press **ENTER** and **↑** or **↓** at the same time to adjust the best display contrast

Hint:

Only in MEASUREMENT menu.

How to check the serial number and software revision?

Press **ENTER** and then **PAGE**. On the display you can see IntelliLite INFO screen for 10 seconds.

IntelliLite INFO screen contains :

- 1) *Controller name* (see **Basic setting** group)
- 2) IntelliLite serial number (8 character number)
- 3) SW version: the first is the firmware version number, the second is configuration table number.
- 4) Application: MRS16
- 5) Branch: Standard

Hint:

Only in MEASUREMENT menu.

How to change language?

Press **ENTER** and then **PAGE** to get to Serial number and software revision screen. Then press **PAGE** to enter Language selection screen. Use **↑** or **↓** to select desired language and press **ENTER** to confirm selection.

How to find active alarms ?

Active alarm list is the last screen in the MEASUREMENT menu.

Select MEASUREMENT menu. Press  You will see the list of all active alarms with the number of alarms at the top-right corner Three state alarms are introduced:

	Description
* Wrn Water temp	Active not accepted alarm
Wrn water temp	Active accepted alarm
* Wrn Water temp	Inactive not accepted alarm
	Inactive accepted alarm

Press **FAULT RESET** accepts all alarms. Non-active alarms immediately disappear from the list. Active alarm list appears on the screen when a new alarm comes up and Main MEASUREMENT screen is active.

Hint:

Alarm list does not activate when you are reviewing the values or setpoints.

Second alarm list for ECU alarms is also available. It is displayed one screen above the standard alarm list on the controller display or under the standard alarm list in Control window of LiteEdit. If an alarm appears in this alarm list, it is signaled in the standard alarm list and by exclamation mark on the main measure screen.

Control from the front panel:

↑↓	One screen up/down
Enter	Cursor move within the ECU alarm list
Enter + Fault reset	ECU fault code reset

MEASUREMENT screens description

Main measure screen

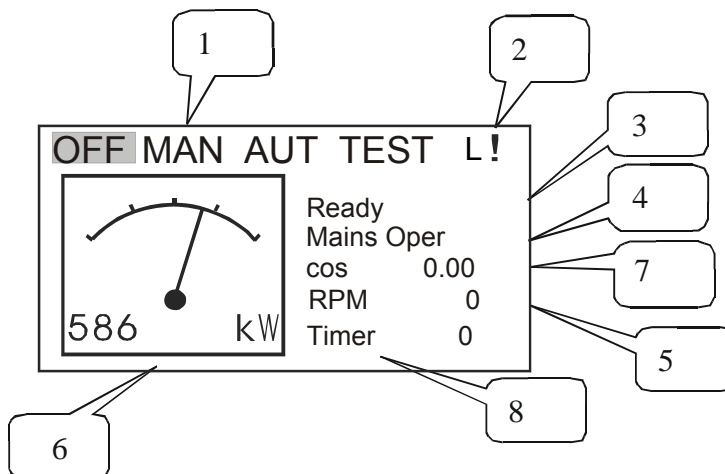

1. Operation mode of the gen-set
2. Indication of active access lock, Remote OFF or Remote TEST L and alarm !
3. Status of the gen-set
- 4.
5. RPM of the gen-set
6. Active power
7. Power factor
8. Timer - event s counting time (e.g. prestart, cooling, etc.)

Generator screen

Gen freq

Gen V1-2, V2-3, V3-1 ph-ph
 Gen V1, V2, V3 ph-N (triple bargraph)
 Gen I1, I2, I3 (triple bargraph)

IL-NT Analog inputs screen

Oil pressure (single bargraph)
 Water temperature (single bargraph)
 Fuel level (single bargraph)
 Battery voltage (single bargraph)

IL-NT binary inputs

BI1 to BI6

IL-NT binary outputs

BO1 to BO6

*ECU state

ECU YellowLamp
 ECU RedLamp
 WaitToStart

Hint:

This screen is shown/hidden depending on whether the ECU is configured or not.

*ECUValues

Oil press
 Water temp
 PercLoadAtCS
 Boost pressure
 ManifoldTemp
 Fuel rate

Hint:

This screen is shown/hidden depending on whether the ECU is configured or not.

Gen-set power screen

Active power (total and per phase)
 Power factor (total and per phase)
 React power (total and per phase)
 Appar power (total and per phase)

Statistic

Run hours
 Number of starts

*Kilowatt-hours kWh (total)
 *Reactive power hours kVAh (total only)

NextServTime

Hint:

Running time is measured in complete minutes, displayed in complete hours. Values are stored in nonvolatile memory.

*ECU AlarmList

Diagnostic messages are read from ECU and displayed in this second alarm list. For Standard J1939 engines SPN (Suspect Parameter Number), FMI (Failure Mode Identifier) and OC (Occurrence Counter) are shown together with verbal description if available.

Following image shows displaying of ECU alarms in the second alarm list. The additional information for the row selected by cursor is on the last row (SPN, OC and FMI codes).
If the verbal description of alarm is not available, the SPN (decimal and hexadecimal) is displayed.

EngOilPress	WRN
BoostPress	FLS
EngOilTemp	FLS
629(275h)	FLS
Controller#1	
EngCoolTemp	WRN
SPN:110 OC:7 FMI:3	

Hint:

For FMI = 0 and 1, WRN is displayed. For other FMI codes, FLS is displayed.

Alarm list

Chart guide to menus and pushbutton's operation

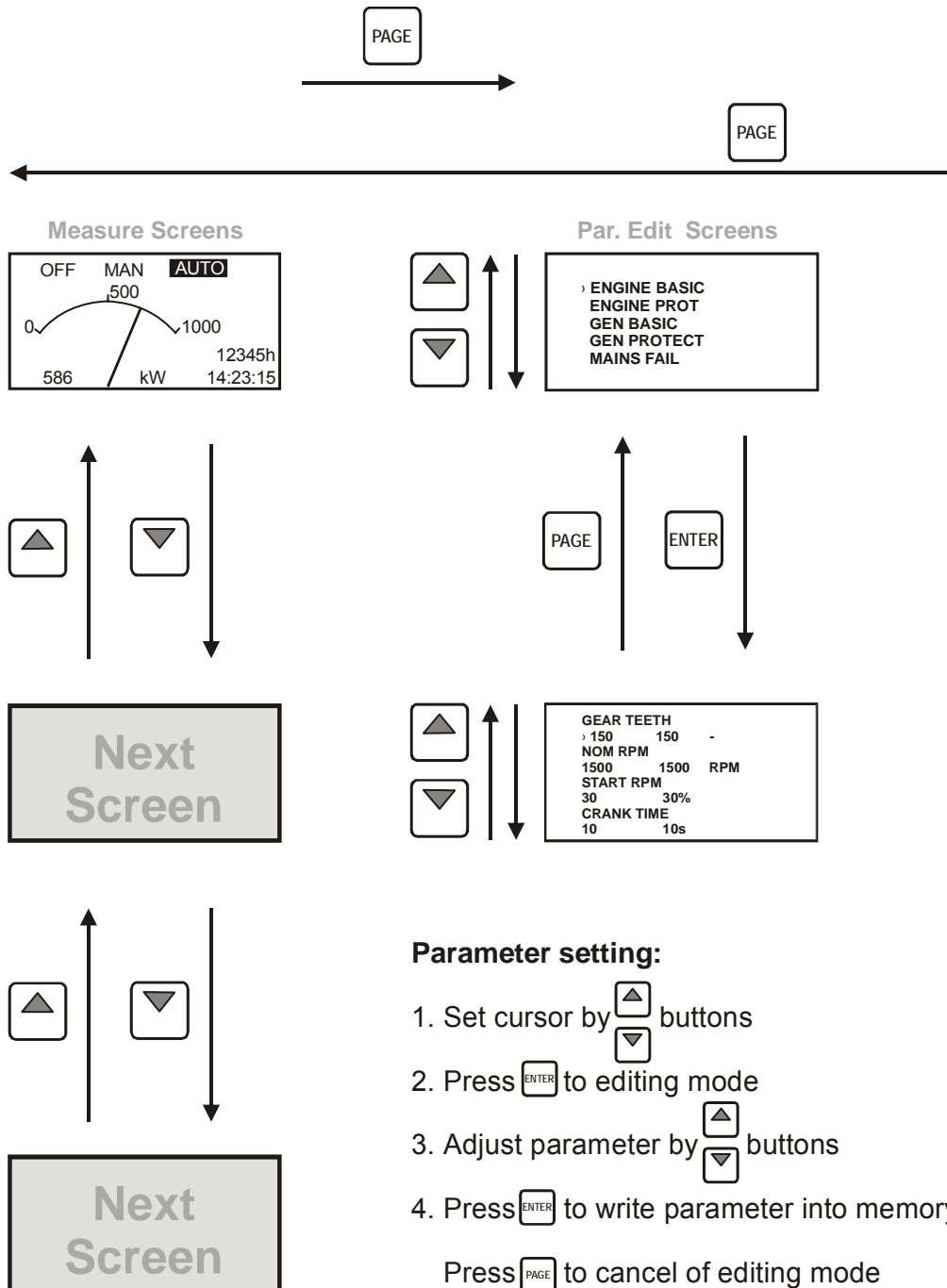

Function description

OFF mode

No start of the gen-set is possible. Outputs STARTER, GCB CLOSE/OPEN and FUEL SOLENOID are not energized.

No reaction if buttons **START**, **STOP**, **GCB ON/OFF** are pressed.

MAN mode

START - starts the gen-set.

GCB ON/OFF

- The controller closes GCB.
- The controller opens GCB when closed.
- If the generator voltage is out of the limits, the controller does not to respond to the **GCB ON/OFF**

STOP stops the gen-set.

Hint:

The engine can run without load unlimited time.

The controller does not automatically stop the running gen-set in MAN mode.

The controller does not start the gen-set when binary input REM START/STOP is closed.

Start-stop sequence (simplified)

MODE = MAN (Engine start/stop request is given by pressing buttons **START** and **STOP**)

MODE = AUT (Engine start/stop request is given by binary input REM START/STOP)

State	Condition of the transition	Action	Next state
Ready	Start request	PRESTART on Prestart time counter started	Prestart
	RPM > 2 or Oil pressure detected or Gen voltage > 10V or D+ is active		Stop (Stop fail)
	OFF mode selected or Shut down alarm active		Not Ready
Not Ready	RPM < 2, Oil pressure not detected, Vgen < 10V, D+ not Active, no shutdown alarm active, other than OFF mode selected		Ready
Prestart ³	Prestart time elapsed	STARTER on FUEL SOLENOID on ⁴ MaxCrank time counter started	Cranking
Cranking ³	RPM > Start RPM	STARTER off PRESTART off	Starting
	D+ input activated for 1s or oil pressure detected or Gen voltage > 25% Vgnom	STARTER off PRESTART off	Cranking

State	Condition of the transition	Action	Next state
	MaxCrank time <i>elapsed, 1st attempt</i>	STARTER <i>off</i> FUEL SOLENOID <i>off</i> STOP SOLENOID <i>on</i> CrankFail pause timer started	Crank pause
	MaxCrank time <i>elapsed, last attempt</i>	STARTER <i>off</i> PRESTART <i>off</i>	Shutdown (Start fail)
Crank pause ³	CrankFail pause <i>elapsed</i>	STARTER <i>on</i> FUEL SOLENOID <i>on</i> ⁴ STOP SOLENOID <i>off</i> MaxCrank time counter started	Cranking
Starting ³	80% Nominal speed <i>reached</i>	READY TO LOAD <i>on</i> ¹ Min, MaxStabTime counter started	Running
	RPM = 0 or any other shutdown condition	FUEL SOLENOID <i>off</i> STOP SOLENOID <i>on</i>	Shutdown
	60 sec. <i>Elapsed</i>	FUEL SOLENOID <i>off</i> STOP SOLENOID <i>on</i>	Shutdown (Start fail)
Running	Stop request	READY TO LOAD <i>off</i> Cooling time timer started	Cooling
	RPM = 0 or any other shutdown condition	READY TO LOAD <i>off</i> ² FUEL SOLENOID <i>off</i>	Shutdown
	GCB CLOSE/OPEN <i>closed</i>		Loaded
Loaded	GCB CLOSE/OPEN <i>opened</i>		Running
	RPM = 0 or any other shutdown condition	FUEL SOLENOID <i>off</i> STOP SOLENOID <i>on</i> READY TO LOAD <i>off</i>	Shutdown
Cooling	Cooling time <i>elapsed</i>	FUEL SOLENOID <i>off</i> STOP SOLENOID <i>on</i>	Stop
	RPM = 0 or any other shutdown condition	FUEL SOLENOID <i>off</i> STOP SOLENOID <i>on</i>	Shutdown
	Start request	READY TO LOAD <i>on</i> ¹	Running
Stop	RPM = 0, Oil pressure not detected, Vgen < 10V, D+ not active		Ready
	60 sec. <i>Elapsed</i>		Stop (Stop fail)

¹ if all generator parameters OK and MinStab Time elapsed, indicates that GCB is possible to close. In AUT mode closes in this moment GCB automatically.

² If GCB output used GCB opens automatically

³ The start-up sequence can be interrupted in any time by coming stop request

⁴ Fuel solenoid is switched on with time advance of 1s fixed before starter motor is switched on.

Hint:

Threshold level for D+ input is 80% supply voltage, activation delay is 1s (to override short firings during during cranking – for example in cold conditions).

AUT mode

The controller does not respond to buttons **START**, **STOP**, **GCB ON/OFF**. Engine start/stop request is given by binary input REM START/STOP.

Alarm management

Following alarms are available:

- Sensor fail
- Warning
- Shut down

Sensor fail (FLS)

Sensor fail is detected when measured value is 6% out of selected sensor characteristic. Sensor fail is indicated by ##### symbol instead measured value.

Warning (WRN)

When warning comes up, only alarm outputs and common warning output are closed.

Possible warnings:

See [List of possible events](#)

Shut down (SD)

When the shut-down alarm comes up, IntelliLite opens outputs GCB CLOSE/OPEN, FUEL SOLENOID, STARTER and PRESTART to stop the engine immediately. Alarm outputs and common shutdown output are closed. Active or not reset protection disables start.

Possible shut-down alarms:

See [List of possible events](#)

Alarm time chart

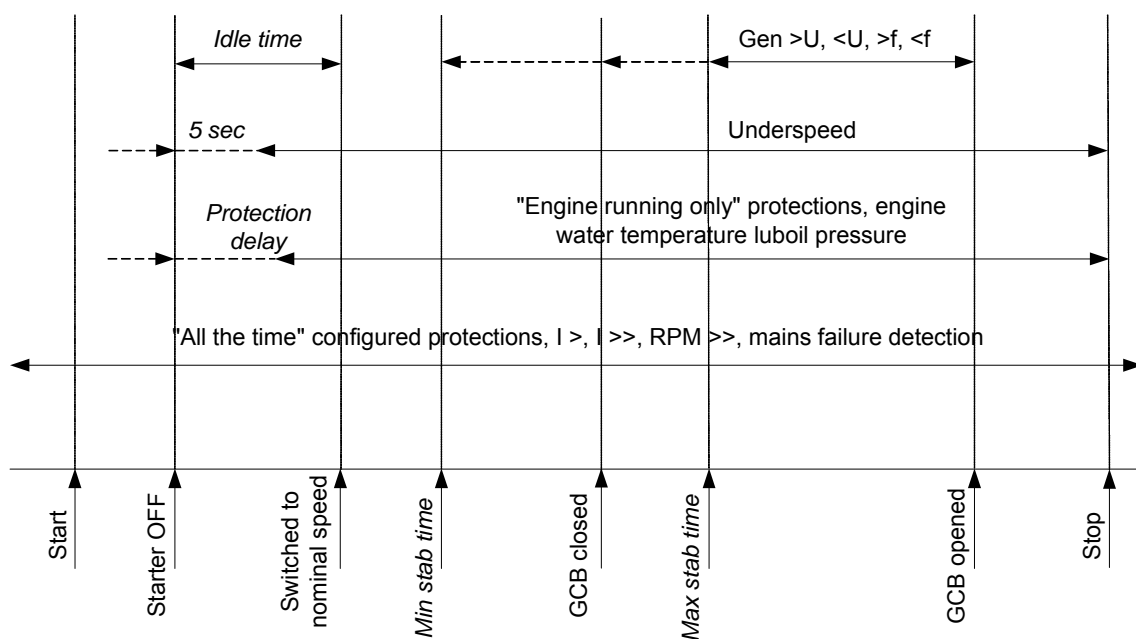

Voltage phase sequence detection

InteliLite controller detects phase sequence on generator voltage terminals. This protection is important after controller installation to avoid wrong voltage phases phase connection. Following alarms can be detected:

Wrong phase sequence

There is fix defined phase sequence in InteliLite controller L1, L2, L3. When the phases are connected in different order (e.g. L1,L3,L2 or L2,L1,L3) following alarms are detected:

G ph opposed = wrong generator phase sequence

Inverted phase polarity

inverted phase polarity can be detected due to wrong connection of separation transformers between controller and generator / mains / bus voltage. Phase sequence is OK but some phase(s) is connected in opposite way (180° shift).

Following alarms can be detected:

GEN L1 neg = generator phase L1 is inverted

GEN L2 neg = generator phase L2 is inverted

GEN L3 neg = generator phase L3 is inverted

Wrong phase sequence and inverted polarity

It is combination of both previous alarms

G ph+L1 neg = wrong generator phase sequence and phase L1 is inverted

G ph+L2 neg = wrong generator phase sequence and phase L2 is inverted

G ph+L3 neg = wrong generator phase sequence and phase L3 is inverted

Hint:

Phase sequence detection is active when voltage in all three phases is $>50\text{VAC}$ and all phases angles are in the range $120^\circ \pm 20$.

Phase sequence alarm detection is 1 sec delayed to avoid transient effects.

Sensor fail detection

Sensor fail FIs is detected when measured value is 6 percent out of range. Controller screen displays in this case string ##### instead measured value.

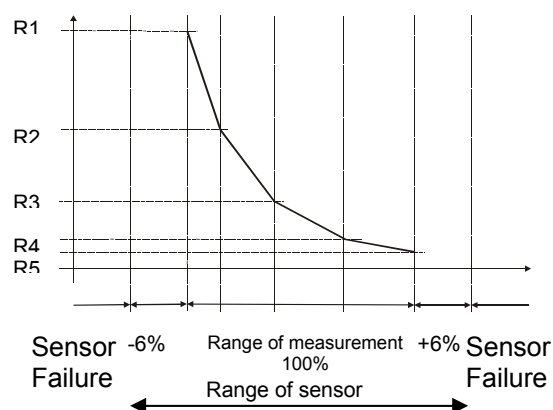

Gen-set operation states

Engine state machine

Init	Autotest during controller power on
Not ready	Genset is not ready to start
Prestart	Prestart sequence in process, Prestart output is closed
Cranking	Engine is cranking
Pause	Pause between start attempts
Starting	Starting speed is reached and the <i>Idle timer</i> is running
Running	Genset is running at nominal speed
Loaded	Genset is running at nominal speed and GCB OPEN/CLOSE is closed
Stop	Stop
Shutdown	Shut-down alarm activated
Ready	Genset is ready to run
Cooling	Genset is cooling before stop
EmergMan	Emergency Manual gen-set operation
AFterCool	Engine aftercooling, CoolingPump output is closed

Electric state machine

MinStabTO	Minimal Stabilization Timeout
MaxStabTO	Maximal Stabilization Timeout
FwRet Brk	Forward return break delay. Delay between GCB opening and MCB closing

List of possible alarms

Events specification	Protection type	Information on binary output available (See list of Binary outputs)	Description
Oil Press Wrn	WRN	YES	Oil pressure is smaller than <i>Wrn Oil press</i> setpoint.
Oil Press Sd	SD	NO	Oil pressure is smaller than <i>Sd Oil press</i> setpoint.
Engine Temp Wrn	WRN	YES	Water temperature is greater than <i>Wrn Water temp</i> setpoint.
Engine Temp Sd	SD	NO	Water temperature is greater than <i>Sd Water temp</i> setpoint.
Fuel Level Wrn	WRN	YES	Fuel level is smaller than <i>Wrn Fuel Level</i> setpoint.
Fuel Level Sd	SD	NO	Fuel level is smaller than <i>Sd Fuel Level</i> setpoint.
Ubat	WRN	YES	Battery voltage is out of limits given by <i>Batt overvolt</i> and <i>Batt undervolt</i> setpoints.
AnInIOM Wrn	WRN	YES	Warning alarm configurable on the input of IG-IOM/IGS-PTM.

Events specification	Protection type	Information on binary output available (See list of Binary outputs)	Description
AnInIOM Sd	SD	YES	Shutdown alarm configurable on the input of IG-IOM/IGS-PTM.
Binary input	Configurable	YES	Configurable Warning/Shutdown alarms on the inputs of IL-NT.
Battery flat	SD	YES	If the controller switches off during starting sequence due to bad battery condition it doesn't try to start again and activates this protection.
Start failed	SD	YES	Gen-set start failed.
ParamFail	NONE	NO	Wrong checksum of parameters. Happends typically after downloading new firmware or changing of the parameter. The controller stays in INIT mode. Check all parameters, write at least one new parameter.
Vgen <, >	SD	YES	The generator voltage is out of limits given by <i>Gen <V</i> and <i>Gen >V</i> setpoints.
Vgen unbl	SD	NO	The generator voltage is unbalanced more than the value of <i>Volt unbal</i> setpoint.
Fgen <,>	SD	YES	The generator frequency is out of limits given by <i>Gen >f</i> and <i>Gen <f</i> setpoints.
Igen unbl	SD	NO	The generator current is unbalanced.
Overload	SD	YES	The load is greater than the value given by <i>Overload</i> setpoint.
Overspeed	SD	YES	The protection comes active if the speed is greater than <i>Overspeed</i> setpoint.
Underspeed	SD	YES	During starting of the engine when the RPM reache the value of <i>Starting RPM</i> setpoint the starter is switched off and the speed of the engine can drop under <i>Start RPM</i> again. Then the Underspeed protection becomes active. Protection evaluation starts 5 seconds after reaching <i>StartingRPM</i> .
EmergencyStop	SD	NO	If the input <i>Emergency stop</i> is opened shutdown is immediately activated.
GCB fail	SD	NO	Failure of generator circuit breaker.
PickupFault	SD	NO	Failure of magnetic pick-up sensor for speed measurement.
Stop fail	SD	YES	Gen-set stop failed.
WrnServiceTime	WRN	NO	The period for servicing is set by the <i>NextServTime</i> setpoint. The protection comes active if the running hours of the engine reach this value.
ChrgAlternFail	WRN	YES	Failure of alternator for charging the battery.
SprinklActive	WRN	NO	The protection is active if the output <i>Sprinkler</i> is closed.
*Wrn RA15 fail	WRN	NO	Warning alarm in case of lost connection to IGL-RA15 module.
*Sd IOM fail	SD	NO	Shutdown alarm in case of lost connection to IG-IOM/IGS-PTM

Events specification	Protection type	Information on binary output available (See list of Binary outputs)	Description
			module.
Wrn ECU Alarm	WRN	NO	ECU alarm list is not empty
Low BackupBatt	WRN	NO	RTC backup battery is flat

History file

InteliLite NT stores a record of each important event into the history file. The history file seats 117 records. When the history file is full, the oldest records are removed.

Hint:

To force history download in LiteEdit (direct,,modem or Internet) open History window and select History | Read history command.

Record structure

Abbreviation	Historical value
Num	Number of historical event
Reason	Event specification
Date	Date of historical event in format DD/MM/YY
Time	Time of historical event in format HH:MM:SS
RPM	Engine speed
Pwr	Generator active power
PF	Generator PF
LChr	Character of the load
Gfrq	Generator frequency
Vg1	Generator voltage L1
Vg2	Generator voltage L2
Vg3	Generator voltage L3
Ig1	Generator current L1
Ig2	Generator current L2
Ig3	Generator current L3
UBat	Battery voltage
OilP	IL-NT Analog input 1 value (default Oil pressure)
EngT	IL-NT Analog input 2 value (default Water temperature)
FLvl	IL-NT Analog input 3 value (default Fuel level)
AIM1	IG-IOM, IGS-PTM Analog input 1 value (when configured IG-IOM, IGS-PTM)
AIM2	IG-IOM, IGS-PTM Analog input 2 value (when configured IG-IOM, IGS-PTM)
AIM3	IG-IOM, IGS-PTM Analog input 3 value (when configured IG-IOM, IGS-PTM)
AIM4	IG-IOM, IGS-PTM Analog input 4 value (when configured IG-IOM, IGS-PTM)
BIN	Binary inputs IL-NT
BIM	IG-IOM, IGS-PTM Binary inputs (when configured IG-IOM, IGS-PTM)
BOUT	Binary inputs IL-NT
BOM	IG-IOM, IGS-PTM Binary outputs (when configured IG-IOM, IGS-PTM)
FC	ECU alarm FailureCode
FMI	ECUalarm Failure Mode Identifier

Remote control and data logging

Direct connection to the PC

InteliLite can be connected directly with PC via optional IL-NT RS232 interface.
Use the standard serial cable to connect PC with InteliLite.

Hint:

Make sure the grounding system on controller and PC – COM port (negative of the PC DC supply) are identical – before the first direct connection. There must not be any voltage between these two points otherwise the internal reversible fuse in controller burns out. The simple solution is to assure, that the PC supply 240/20V is ground free (GND terminal is not connected).

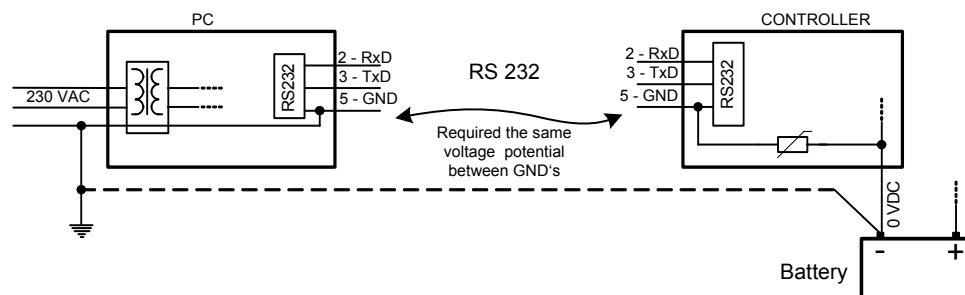

PC software - LiteEdit

On the PC (for direct or modem connection) has to be installed the ComAp's software package LiteEdit. (based on Windows 95 or newer platform)

LiteEdit enables:

- read the quantities
- adjust all set points
- control the engine
- configure the controller
- select software configuration
- modify alarm inputs and outputs
- modify password, commands protections
- direct, modem or Internet communication

Modbus protocol

The selection of the function of IL serial port is done via the setpoint *RS232 mode* in *Basic settings*

- 9600 bps, 8 data bits, 1 stop bit, no parity
- Transfer mode RTU
- Function 3 (Read Multiple Registers)
- Function 6 (Write Single Register)
- Function 16 (Write Multiple Registers)
- The response to an incoming message is sent with minimum 4.096 ms delay after message reception

The complete description of Modbus communication protocol can be found in *Modbus Protocol Reference Guide PI-MBUS-300* and *Open Modbus Specification Release 1.0*. Both documents are available from web site at <http://www.modicon.com/openmbus/>.

Communication object vs. Register

All the data intended for communication has its representation as communication objects in the controller. The communication object is represented by the n-byte array in the controller memory and identified by the unique 16-bit communication object number. The register, according to Modbus communication protocol, represents a two-byte data and in communication functions is referenced by 16-bit register address. Further in the description of communication functions **the communication object number will always be used as a register address** and length of the communication object will be expressed by number of registers. **Just one communication object can be read or written by one communication function.**

Hint:

To obtain communication object numbers it is possible to download the actual controller description on-line from controller or from (ail) archive and use "export data" function from LiteEdit software.

Communication object list (exported from default IL-NT-MRS16 archive)

Setpoints (MRS16):

Name	Firmware ver.	Application	Date	App. ver.	Ser. num.	Filename			
IL-NT	IL-NT-1.0 R:26.07.2007	MRS16	14.8.2007	1,0	1234567	IL-NT-MRS16-1.0.AIL			

Group	Name	Value	Dimension	Password	Com. obj.	Low limit	High limit	Data type
Basic settings	Gen-set name	IL-NT		0	8637			Short string
Basic settings	Nomin power	200	kW	0	8276	1	32000	Unsigned 16
Basic settings	Nomin current	350	A	0	8275	1	10000	Unsigned 16
Basic settings	CT ratio	2000	/5A	0	8274	1	5000	Unsigned 16
Basic settings	PT ratio	1,0	/1	0	9579	0,1	500,0	Unsigned 16
Basic settings	Nomin voltage	231	V	0	8277	80	20000	Unsigned 16
Basic settings	Nominal freq	50	Hz	0	8278	45	65	Unsigned 16
Basic settings	Gear teeth	120		0	8252	0	500	Unsigned 16
Basic settings	Nominal RPM	1500	RPM	0	8253	100	4000	Unsigned 16
Basic settings	ControllerMode	OFF		0	8315			String list
Basic settings	FitResGoToMAN	DISABLED		0	9983			String list
Basic settings	DispBaklightTO	15	min	0	10121	0	241	Unsigned 8
Basic settings	Contr. addr	1		3	24537	1	32	Unsigned 8
Basic settings	RS232 mode	STANDARD		3	24522			String list
Engine params	Starting RPM	25	%	0	8254	5	50	Unsigned 8
Engine params	Starting POil	4,5	Bar	0	9681	0,0	10,0	Integer 16
Engine params	Prestart time	2	s	0	8394	0	600	Unsigned 16
Engine params	MaxCrank time	5	s	0	8256	1	60	Unsigned 8
Engine params	CrnkFail pause	8	s	0	8257	5	60	Unsigned 8
Engine params	Crank attempts	3		0	8255	1	10	Unsigned 8
Engine params	Idle time	12	s	0	9097	0	600	Unsigned 16
Engine params	Min stab time	2	s	0	8259	1	10	Unsigned 16
Engine params	Max stab time	10	s	0	8313	2	300	Unsigned 16
Engine params	Cooling speed	NOMINAL		0	10046			String list

Engine params	Cooling time	30	s	0	8258	0	3600	Unsigned 16
Engine params	AfterCool time	180	s	0	8662	0	3600	Unsigned 16
Engine params	Stop time	60	s	0	9815	0	240	Unsigned 16
Engine params	Fuel solenoid	DIESEL		0	9100			String list
Engine params	D+ function	DISABLED		0	9683			String list
Engine params	ECU FreqSelect	DEFAULT		0	10266			String list
Engine params	ECU SpeedAdj	50	%	0	9948	0	100	Unsigned 16
Engine protect	Eng prot del	5	s	0	8262	0	300	Unsigned 16
Engine protect	Horn timeout	10	s	0	8264	0	600	Unsigned 16
Engine protect	Overspeed	115	%	0	8263	50	150	Unsigned 16
Engine protect	AnlInp1 level1	2,0	Bar	0	8369	-10,0	1000,0	Integer 16
Engine protect	AnlInp1 level2	1,0	Bar	0	8370	-10,0	1000,0	Integer 16
Engine protect	AnlInp1 del	3	s	0	8365	0	180	Unsigned 16
Engine protect	AnlInp2 level1	80	°C	0	8375	-100	10000	Integer 16
Engine protect	AnlInp2 level2	90	°C	0	8376	-100	10000	Integer 16
Engine protect	AnlInp2 del	5	s	0	8371	0	180	Unsigned 16
Engine protect	AnlInp3 level1	20	%	0	8381	-100	10000	Integer 16
Engine protect	AnlInp3 level2	10	%	0	8382	-100	10000	Integer 16
Engine protect	AnlInp3 del	10	s	0	8377	0	180	Unsigned 16
Engine protect	Batt overvolt	36,0	V	0	9587	18,0	40,0	Integer 16
Engine protect	Batt undervolt	18,0	V	0	8387	8,0	36,0	Integer 16
Engine protect	Batt volt del	5	s	0	8383	0	600	Unsigned 16
Engine protect	NextServTime	65534	h	0	9648	0	65535	Unsigned 16
Gener protect	Overload	120	%	0	8280	0	200	Unsigned 16
Gener protect	Overload del	5,0	s	0	8281	0,0	600,0	Unsigned 16
Gener protect	Ishort	250	%	0	8282	100	500	Unsigned 16
Gener protect	Ishort del	0,00	s	0	9991	0,00	10,00	Unsigned 16
Gener protect	2Inom del	4,0	s	0	8283	1,0	60,0	Unsigned 16
Gener protect	Curr unbal	50	%	0	8284	1	200	Unsigned 16
Gener protect	Curr unbal del	5,0	s	0	8285	0,0	600,0	Unsigned 16
Gener protect	Gen >V Sd	110	%	0	8291	70	200	Unsigned 16
Gener protect	Gen <V Sd	70	%	0	8293	0	110	Unsigned 16
Gener protect	Gen V del	3,0	s	0	8292	0,0	600,0	Unsigned 16
Gener protect	Volt unbal	10	%	0	8288	1	200	Unsigned 16
Gener protect	Volt unbal del	3,0	s	0	8289	0,0	600,0	Unsigned 16
Gener protect	Gen >f	110,0	%	0	8296	85,0	200,0	Unsigned 16
Gener protect	Gen <f	85,0	%	0	8298	0,0	110,0	Unsigned 16
Gener protect	Gen f del	3,0	s	0	8297	0,0	600,0	Unsigned 16
Date/Time	Time stamp per	60	min	0	8979	0	240	Unsigned 8
Date/Time	SummerTimeMod	DISABLED		0	8727			String list
Date/Time	Time	0:00:00		0	24554			Time

Date/Time	Date	1.1.2006		0	24553			Date
Date/Time	Timer1 repeat	NONE		0	10045			String list
Date/Time	Timer1 ON time	5:00:00		0	10042			Time
Date/Time	Timer1Duration	5	min	0	10044	1	1440	Unsigned 16
Date/Time	Timer2 repeat	NONE		0	10202			String list
Date/Time	Timer2 ON time	5:00:00		0	10199			Time
Date/Time	Timer2Duration	5	min	0	10201	1	1440	Unsigned 16
Sensors spec	Calibr AI 1	0,0	Bar	0	8431	-100,0	100,0	Integer 16
Sensors spec	Calibr AI 2	0	°C	0	8407	-1000	1000	Integer 16
Sensors spec	Calibr AI 3	0	%	0	8467	-1000	1000	Integer 16
Sensors spec	CalibrAIInIOM 1	0	U4	0	8793	-1000	1000	Integer 16
Sensors spec	CalibrAIInIOM 2	0	U5	0	8794	-1000	1000	Integer 16
Sensors spec	CalibrAIInIOM 3	0	U6	0	8795	-1000	1000	Integer 16
Sensors spec	CalibrAIInIOM 4	0	U7	0	8796	-1000	1000	Integer 16
IOM/PTM module	AnInIOM1 lev1	0	U4	0	8762	-100	10000	Integer 16
IOM/PTM module	AnInIOM1 lev2	0	U4	0	8766	-100	10000	Integer 16
IOM/PTM module	AnInIOM1 del	5	s	0	8770	0	180	Unsigned 16
IOM/PTM module	AnInIOM2 lev1	0	U5	0	8763	-100	10000	Integer 16
IOM/PTM module	AnInIOM2 lev2	0	U5	0	8767	-100	10000	Integer 16
IOM/PTM module	AnInIOM2 del	5	s	0	8771	0	180	Unsigned 16
IOM/PTM module	AnInIOM3 lev1	0	U6	0	8764	-100	10000	Integer 16
IOM/PTM module	AnInIOM3 lev2	0	U6	0	8768	-100	10000	Integer 16
IOM/PTM module	AnInIOM3 del	5	s	0	8772	0	180	Unsigned 16
IOM/PTM module	AnInIOM4 lev1	0	U7	0	8765	-100	10000	Integer 16
IOM/PTM module	AnInIOM4 lev2	0	U7	0	8769	-100	10000	Integer 16
IOM/PTM module	AnInIOM4 del	5	s	0	8773	0	180	Unsigned 16

Values (MRS16):

Name	Firmware ver.	Application	Date	App. ver.	Ser. num.
IL-NT	IL-NT-1.0 R:26.07.2007	MRS16	14.8.2007	1,0	12345678

Group	Name	Value	Dimension	Com. obj.	Data type
Engine params	ECU State	[010]		10034	Binary 8
Engine params	Fuel rate	0,0	L/h	9860	Unsigned 16
Engine params	Water temp	22	°C	9855	Integer 16
Engine params	ManifoldTemp	20	°C	9878	Integer 16
Engine params	Oil Pressure	0,0	Bar	10354	Integer 16
Engine params	Boost pressure	0,0	Bar	9877	Unsigned 8
Engine params	PercLoadAtCS	0	%	9925	Unsigned 8

Engine values	RPM	1500	RPM	8209	Unsigned 16
Statistics	kWhours	0	kWh	8205	Integer 32
Statistics	kVAhrs	0	kVAh	8539	Integer 32
Statistics	Run hrs	0	h	8206	Integer 32
Statistics	Num starts	0		8207	Unsigned 16
Statistics	NextServTime	#####	h	9648	Unsigned 16
Statistics	E-Stop	0		11195	Unsigned 32
Statistics	ShutDown	0		11196	Unsigned 32
Analog CU	Ubat	24,3	V	8213	Integer 16
Analog CU	CPU temp	37,1	°C	10124	Integer 16
Analog CU	D+	5,7	V	10603	Integer 16
Analog CU	Oil Pressure	15,6	Bar	8227	Integer 16
Analog CU	Engine Temp	50	°C	8228	Integer 16
Analog CU	Fuel level	99	%	8229	Integer 16
Generator	Act power	150	kW	8202	Integer 16
Generator	Act pwr L1	50	kW	8524	Integer 16
Generator	Act pwr L2	50	kW	8525	Integer 16
Generator	Act pwr L3	50	kW	8526	Integer 16
Generator	React pwr	15	kVAr	8203	Integer 16
Generator	React pwr L1	5	kVAr	8527	Integer 16
Generator	React pwr L2	5	kVAr	8528	Integer 16
Generator	React pwr L3	5	kVAr	8529	Integer 16
Generator	Appar pwr	153	kVA	8565	Integer 16
Generator	Appar pwr L1	51	kVA	8530	Integer 16
Generator	Appar pwr L2	51	kVA	8531	Integer 16
Generator	Appar pwr L3	51	kVA	8532	Integer 16
Generator	Pwr factor	1,00		8204	Integer 8
Generator	Load char	R		8395	Char
Generator	Pwr factor L1	1,00		8533	Integer 8
Generator	Load char L1	R		8626	Char
Generator	Pwr factor L2	1,00		8534	Integer 8
Generator	Load char L2	R		8627	Char
Generator	Pwr factor L3	1,00		8535	Integer 8
Generator	Load char L3	R		8628	Char
Generator	Gen freq	50,0	Hz	8210	Unsigned 16
Generator	Gen V L1-N	230	V	8192	Unsigned 16
Generator	Gen V L2-N	230	V	8193	Unsigned 16
Generator	Gen V L3-N	230	V	8194	Unsigned 16
Generator	Gen V L1-L2	398	V	9628	Unsigned 16
Generator	Gen V L2-L3	398	V	9629	Unsigned 16

Generator	Gen V L3-L1	398	V	9630	Unsigned 16
Generator	Gen curr L1	41	A	8198	Unsigned 16
Generator	Gen curr L2	41	A	8199	Unsigned 16
Generator	Gen curr L3	41	A	8200	Unsigned 16
Binary I/O	BIN	[1111001]		8235	Binary 16
Binary I/O	BinpIOM	[01000110]		8602	Binary 16
Binary I/O	BOUT	[111100]		8239	Binary 16
Binary I/O	BOutRA15	[1000100100000000]		9849	Binary 16
Binary I/O	BOutIOM	[11011001]		8604	Binary 16
Date/Time	Time	#####		24554	Time
Date/Time	Date	#####		24553	Date
IL info	Engine state	#####		8330	Unsigned 16
IL info	Breaker state	#####		8455	Unsigned 16
IL info	Timer text	#####		8954	Unsigned 16
IL info	Timer val	0	s	8955	Unsigned 16
IL info	SW version	0,0		8393	Unsigned 8
IL info	Application	4		8480	Unsigned 8
IL info	SW branch	1		8707	Unsigned 8
IL info	PasswordDecode	#####		9090	Unsigned 32
IOM/PTM module	AnInIOM 1	10	U4	8978	Integer 16
IOM/PTM module	AnInIOM 2	20	U5	8759	Integer 16
IOM/PTM module	AnInIOM 3	30	U6	8760	Integer 16
IOM/PTM module	AnInIOM 4	40	U7	8761	Integer 16

¹ In case of software malfunction DiagData shows the value that enables to locate possible bug in software. Include this number when reporting a software problem.

Remote communication

Note:

Refer to IntelliCommunication guide for all additional information.

Internet connection

IL-NT controllers can be monitored from LiteEdit 3.0 over the Internet using Internet Bridge (IG-IB) connected to the controller RS232 port.

Recommended ISDN modem

- Askey TAS-200E
- ASUScom TA-220ST
- Develo Microlink ISDN i

Recommended GSM modem

- Siemens M20, TC35, TC35i, ES75, MC39
- Wavecom M1200/WMOD2
- Wavecom - Maestro 20, dual 900/1800MHz.
- Wavecom – Fastrack M1306B, dual 900/1800 MHz (Fastrack M1206B is NOT recommended)
- FALCOM A2D, dual 900/1800MHz.

GSM Modem setup

Prior to start work with GSM modem run following program for GSM proper setup.

Program writes all the necessary AT commands to configure the GSM modem properly for use with IL-NT.

This program runs independent on LiteEdit:

- Start MS Windows-Start-Program files - LiteEdit -Gm_setup.exe.
- Select COM port
- Select iG-CU (=IS-CU) or iG-MU unit
- Press Setup button
- Follow commands in GSM Modem Setup window

Typical real baud rate for GSM data communication is 80 to 90 Bps.

Hint:

It is strongly recommended to use the same type of modem on the both sides (IL and PC) of connection.

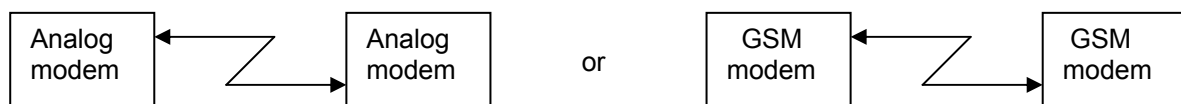

Mobile SIM card setting

- Adjust SIM card in GSM modem following way:
- enable data connection (when required)
- no PIN code

Technical data

Power supply

Voltage supply	8-36V DC
Consumption	40-430mA depend on supply voltage and temperature
Consumption depends on supply voltage	0,104A at 8VDC 0,080A at 12VDC 0,051A at 24VDC 0,044A at 30VDC 0,040A at 36VDC
Allowed supply voltage drop-out:	100ms from min. 10V, return to min. 8V
Battery voltage measurement tolerance	2 % at 24V

Hint:

For the supply voltage less than 7V the backlight of the display is switched off.
Short-term voltage drops (e.g. during the engine cranking) do not affect the operation at all.

Operating conditions

Operating temperature IL-NT	-20..+70°C
Operating temperature IL-NT LT [#]	-40..+70°C
Storage temperature	-30..+80°C
Protection front panel	IP65
Humidity	95% without condensation
Standard conformity	
Low Voltage Directive	EN 61010-1:95 +A1:97
Electromagnetic Compatibility	EN 50081-1:94, EN 50081-2:96 EN 50082-1:99, EN 50082-2:97
Vibration	5 - 25 Hz, ±1,6mm 25 - 100 Hz, a = 4 g
Shocks	a = 200 m/s ²

#Low Temperature modification

LCD display limits controller operating temperature range to -20 °C - + 70 °C even if the other electronic components work in wider temperature range.

Internal preheating foil is mounted in IntelliLite^{NT} LT to extend display operational temperature range. Preheating starts at temperature below 5 °C and preheating power depends on temperature and power supply voltage.

Technical data

	IL-NT Standard	Order code:IL-NT-xxxxx LT
Operating temperature	-20 °C..+70°C	-40 °C..+70°C
Storage temperature	-30 °C..+80°C	-30 °C..+80°C

Preheating foil increases controller current consumption

Controller consumption at	No preheating	Preheating at ambient temperature		
		0 °C	-20 °C	-40 °C
12VDC	80 mA	+75 mA	+210 mA	+325 mA
24VDC	51 mA	+31 mA	+100 mA	+175 mA

InteliLite LT works immediately after switch on at -30 °C and display becomes visible after a few minutes.

Dimensions and weight

Dimensions	180x120x55mm
Weight	450g

Generator

Nominal frequency	50-60Hz
Frequency measurement tolerance	0,2Hz

Current inputs

Nominal input current (from CT)	5 A
Load (CT output impedance)	< 0,1 Ω
CT input burden	< 0,2 VA per phase (In=5A)
Max. measured current from CT	10 A
Current measurement tolerance	2% from the Nominal current
Max. peak current from CT	150 A / 1s
Max. continuous current	12 A

Voltage inputs

Measuring voltage range	0 – 277 VAC phase to neutral 0 – 480 VAC phase to phase
Maximal measured voltage	340 VAC phase to neutral 600 VAC phase to phase
Input resistance	0.6 M Ω phase to phase 0.3 M Ω phase to neutral
Voltage measurement tolerance	2 % from the Nominal voltage
Overvoltage class	III / 2 (EN61010)

Binary inputs and outputs

Binary inputs

Number of inputs	7
Input resistance	4,2 k Ω
Input range	0-36 VDC
Switching voltage level for close contact indication	0-2 V
Max voltage level for open contact indication	8-36 V

Binary open collector outputs

Number of outputs	7
Maximum current	0,5 A
Maximum switching voltage	36 VDC

Analog inputs

Not electrically separated	
Number of inputs	3
Resolution	10 bits
Jumper selectable range	V, Ohm(default), mA
Maximal resistance range	2500 Ω
Maximal voltage range	2.5 V
Current range	0 – 20 mA
Input impedance	180 Ω for mA measuring
Input impedance	> 100 k Ω for V measuring
Resistance measurement tolerance	$\pm 2 \% \pm 2 \Omega$ out of measured value
Voltage measurement tolerance	$\pm 1 \% \pm 1mV$ out of measured value

Current measurement tolerance $\pm 2.5 \% \pm 0,5\text{mA}$ out of measured value

Speed pick-up input

Type of sensor	magnetic pick-up (connection by shielded cable is recommended)
Minimum input voltage	2 Vpk-pk (from 4 Hz to 4 kHz)
Maximum input voltage	50 Veff
Minimum measured frequency	4 Hz
Maximum measured frequency	10 kHz (min. input voltage 6Vpk-pk)
Frequency measurement tolerance	0,2 %

D+ function

Max. D+ output current	300 mA
Guaranteed level for signal Charging OK	80% of supply voltage

***CAN bus interface**

Galvanically separated	
Maximal CAN bus length	200m
Speed	250kBd
Nominal impedance	120Ω
Cable type	twisted pair (shielded)

Following dynamic cable parameters are important especially for maximal 200 meters CAN bus length and 32 iS-COM units connected:

Nominal Velocity of Propagation	min. 75% (max. 4,4 ns/m)
Wire crosscut	min. 0,25 mm ²
Maximal attenuation (at 1 MHz)	2 dB / 100m

Recommended Industrial Automation & Process Control Cables:

BELDEN (see <http://www.belden.com>):

- 3082A DeviceBus for Allen-Bradley DeviceNet
- 3083A DeviceBus for Allen-Bradley DeviceNet
- 3086A DeviceBus for Honeywell SDS
- 3087A DeviceBus for Honeywell SDS
- 3084A DeviceBus for Allen-Bradley DeviceNet
- 3085A DeviceBus for Allen-Bradley DeviceNet
- 3105A Paired EIA Industrial RS485 cable

LAPP CABLE (see <http://www.lappcable.com>)

- Unitronic BUS DeviceNet Trunk Cable
- Unitronic BUS DeviceNet Drop Cable
- Unitronic BUS CAN
- Unitronic-FD BUS P CAN UL/CSA

IL-NT RS232 interface (optional card)

Plugs into IL-NT controller COMMUNICATIN MODULE port.

Maximal distance	10m
Speed	19.2kBd (STD) 9.6kBd (MODBUS)

Recommend external converter:

ADVANTECH – ADAM 4520: RS232 to RS422/485 converter, DIN rail, automatic RS485 bus supervision, no external data flow control signals, galvanic isolated.

Recommended internal converter:

ADVANTECH – PCL-745B or PCL745S : Dual port RS422/485 Interface card, automatic RS485 bus supervision, no external data flow control signals, galvanic isolated

IL-NT AOUT8 interface (optional card)

Plugs into IL-NT controller EXTENSION MODULE port.

Number of PWM outputs	8
PWM frequency	250Hz
Maximum current	0.5 A
Maximum switching voltage	36 VDC
Output resistance	1Ω
Resolution	10 bits

IGS-PTM

Voltage supply	8-36V DC
Consumption	0,1A depend on supply voltage
Mechanical dimensions:	40 x 95 x 45 mm , DIN rail (35 mm) mounted
Interface to controller	CAN
Binary inputs and outputs	see IG-IOM
Analog output	see IG-IOM

Analog inputs

Not electrically separated	
Number of inputs	4
Resolution	10 bits
Maximal resistance range	0 – 250 Ω
Maximal voltage range	0 – 100 mV
Maximal current range	0 – 20 mA
Resistance measurement tolerance	1 % ± 2 Ω out of measured value
Voltage measurement tolerance	1,5 % ± 1mV out of measured value
Current measurement tolerance	2,5 % ±0,5mA out of measured value

IGL-RA15

Power supply

Voltage supply	8-36V DC
Consumption	0,35-0,1A (+1A max horn output) Depend on supply voltage

Operating conditions

Operating temperature	-20..+70°C
Storage temperature	-40..+80°C
Protection front panel	IP65

Dimensions and weight

Dimensions	180x120x55mm
Weight	950g

Horn output

Maximum current	1 A
Maximum switching voltage	36 VDC

IG-IB

Voltage supply	8-36V DC
Consumption	0,1A depend on supply voltage
Mechanical dimensions:	95 x 96 x 43 mm , DIN rail (35 mm) mounted
Interface to controller	RS232
Interface to modem	RS232
Interface to Ethernet	RJ45 (10baseT)
Operating temperature	-30..+70°C
Storage temperature	-30..+70°C