

1008. The Genset Engine.

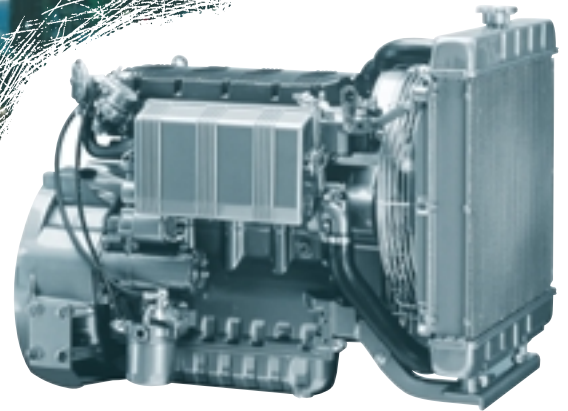

5-32 kVA at 1500/1800/3000/3600 min⁻¹



These are the characteristics of the 1008 GEN:

Naturally aspirated 2-, 3- and 4-cylinder in-line engines.

4-cylinder engine turbocharged too.

Displacement: 0.306 l/cylinder.

Water-cooled engine series.

Innovative injection and combustion system with unit injector for each cylinder.

Customized component system with numerous different peripheral parts.

Compact engine design and minimal weight.

Worldwide service network with over 3,000 locations.

These are the benefits for you:

- ▶ Very low noise emission, high cost savings thanks to less insulation requirement. Can be operated at any time, even at night.
- ▶ Very good load acceptance ensures immediate power supply..
- ▶ Trouble-free continuous operation at 3600 min⁻¹ guarantees reliable working process. Unnecessary downtimes and costs are avoided.
- ▶ High economy together with low operating costs thanks to long service intervals, high reliability and durability.
- ▶ Easy and cost-effective installation thanks to optimal configuration and customized application engineering.

► Technical data

Engine type		F2M 1008				F3M 1008				F4M 1008				BF4M 1008			
Speed	min ¹	1500	1800	3000	3600	1500	1800	3000	3600	1500	1800	3000	3600	1500	1800	3000	3600
Frequency	Hz	50	60	50	60	50	60	50	60	50	60	50	60	50	60	50	60
Engine/genset ratings⁴⁾																	
Continuous power, ICN (COP) ²⁾	kW	4.6	5.5	9.5	10.7	6.8	8.2	14.1	15	9.1	10.9	19.1	20.0	11.8	14.1	25.0	25.9
Prime power, ICN (PRP) ³⁾	kW	–	–	–	–	–	–	–	–	–	–	–	–	–	–	–	–
Limited-time running power, IFN (LTP) ⁴⁾	kW	5.0	6.1	10.4	11.7	7.5	9.0	15.5	16.5	10.0	12.0	21.0	22.0	13.0	15.5	27.5	28.5
Typical generator power output (COP) ⁵⁾	kVA	5.2	6.2	10.7	12.0	7.7	9.2	15.9	16.9	10.2	12.3	21.5	22.5	13.3	15.9	28.1	29.1
Typical generator power output (PRP) ⁵⁾	kVA	–	–	–	–	–	–	–	–	–	–	–	–	–	–	–	–
Typical generator power output (LTP) ⁵⁾	kVA	5.6	6.9	11.7	13.2	8.4	10.1	17.4	18.6	11.3	13.5	23.6	24.8	14.6	17.4	30.9	32.1
Basic engine data																	
Inertia moment J		0.0107				0.0142				0.0153				0.0153			
- Engine without flywheel	kg/m ²	0.0107				0.0142				0.0153				0.0153			
- Flywheel	kg/m ²	0.269	0.269	0.108	0.108	0.269	0.269	0.108	0.108	0.269	0.269	0.108	0.108	0.269	0.269	0.108	0.108
Weight, engine with radiator	kg	95	95	95	95	108	108	108	108	123	123	123	123	131	131	131	131
Governing																	
Governor mechanical		LOM	LOM	LOM	LOM	LOM	LOM	LOM	LOM	LOM	LOM	LOM	LOM	LOM	LOM	LOM	LOM
- Speed droop (static)	%	6	6	6	6	6	6	6	6	6	6	6	6	6	6	6	6
Fuel system																	
Specific fuel consumption at COP ⁶⁾																	
100 % load	g/kWh	275	272	282	300	275	272	280	310	270	270	275	290	270	270	290	300
75 % load	g/kWh	285	290	305	315	290	295	310	335	295	280	285	320	290	280	310	300
50 % load	g/kWh	340	355	345	365	320	355	345	370	330	320	320	350	330	330	340	335
25 % load	g/kWh	390	385	400	400	390	385	400	400	360	360	360	360	400	400	500	500
Cooling system/cooling capacity																	
Coolant volume engine + radiator (HT)	l	3.55	3.55	3.55	3.55	4.35	4.35	4.35	4.35	5.83	5.83	5.83	5.83	7.65	7.65	7.65	7.65
Cooling air volume	m ³ /h	2520	2880	4320	4320	2880	3240	5400	5400	3000	3360	5640	5640	3360	3600	6300	6300
Max. permissible air flow resistance	mbar	1.0	1.0	1.0	1.0	1.0	1.0	1.0	1.0	1.0	1.0	1.0	1.0	1.0	1.0	1.0	1.0
Max. coolant temperature at engine outlet (switch point engine STOP)	°C	110	110	110	110	110	110	110	110	110	110	110	110	110	110	110	110
Heat radiation	kW	–	–	–	–	–	–	–	–	–	–	–	–	–	–	–	–
Lubrication system																	
Lube oil consumption relative to fuel consumption at full load	ca. %	0.7	0.7	0.7	0.7	0.7	0.7	0.7	0.7	0.7	0.7	0.7	0.7	0.7	0.7	0.7	0.7
Lube oil specification		For further details on fuel specification see operation manual															
Lube oil volume, oil pan (max./min.)	l	1.7/1.1		1.7/1.1		2.5/1.5		2.5/1.5		3.4/2.1		3.4/2.1		4.3/2.7		4.3/2.7	
Oil temperature max.	°C	120	120	120	120	120	120	120	120	120	120	120	120	120	120	120	120
Full-flow filter	No./l	1/0.1	1/0.1	1/0.1	1/0.1	1/0.1	1/0.1	1/0.1	1/0.1	1/0.2	1/0.2	1/0.2	1/0.2	1/0.2	1/0.2	1/0.2	1/0.2
Min. oil pressure (alarm)	bar	1.4	1.4	1.4	1.4	1.4	1.4	1.4	1.4	1.4	1.4	1.4	1.4	1.4	1.4	1.4	1.4

► Technical data

Engine type		F2M 1008				F3M 1008				F4M 1008				BF4M 1008			
Speed	min ⁻¹	1500	1800	3000	3600	1500	1800	3000	3600	1500	1800	3000	3600	1500	1800	3000	3600
Frequency	Hz	50	60	50	60	50	60	50	60	50	60	50	60	50	60	50	60

Combustion air system

Combustion air volume (COP)	m ³ /h	23.4	28.2	46.8	56.4	35.4	42.0	70.2	84.0	46.8	56.4	93.6	112.2	55.5	66.0	121.2	145.2
Max. intake vacuum (filter: servicing)	mbar	63.5	63.5	63.5	63.5	63.5	63.5	63.5	63.5	63.5	63.5	63.5	63.5	37.0	37.0	37.0	37.0

Exhaust system

Exhaust gas mass flow at full load (COP)	kg/h	83.5	99.8	166.1	199.7	124.8	149.8	249.6	299.5	166.1	199.7	333.1	399.4	215.3	273	430.6	517
Exhaust temperature at full load and 25°C ambient temperature	°C	-	-	-	-	-	-	-	-	-	-	-	-	-	-	-	-
Max. permissible exhaust backpressure	mbar	50	50	50	50	65	65	65	65	75	75	75	75	75	75	75	75
Exhaust flange	mm	34	34	34	34	40	40	40	40	40	40	40	40	40	40	40	40
TA-Luft (4000)	mg/nm ³	yes	yes	yes	yes	yes	yes	yes	yes	yes	yes	yes	yes	yes	yes	yes	yes

Engine electrics

Electrical equipment:

- Voltage	V	12	12	12	12	12	12	12	12	12	12	12	12	12	12	12	12
- Starter	kW	1.1	1.1	1.1	1.1	1.1	1.1	1.1	1.1	1.1	1.1	1.1	1.1	1.1	1.1	1.1	1.1
- Alternator	A/V	35/14		35/14		35/14		35/14		35/14		35/14		35/14		35/14	
- Battery (min. capacity)	Ah	66	66	66	66	66	66	66	66	66	66	66	66	66	66	66	66

Cold-start capability

Cold-start limit temperature:

- with starting aid	°C	-15	-15	-15	-15	-15	-15	-15	-15	-15	-15	-15	-15	-15	-15	-15	-15
---------------------	----	-----	-----	-----	-----	-----	-----	-----	-----	-----	-----	-----	-----	-----	-----	-----	-----

Noise emission

Sound pressure level	dB(A)/1pW	-	-	-	-	-	-	-	-	-	-	-	-	-	-	-	-
Sound pressure level at full load, 1 m distance	dB(A)	77	79	87	90	79	81	89	92	81	83	91	94	81	83	91	94

- 1) Power reduction caused by altitude and temperature possible. Power ratings without fan power requirement. For more details please contact DEUTZ.
- 2) Continuous power 100% available at flywheel, no time limitation, plus 10% extra power for governing purposes.
- 3) Prime power 100%, permissible average power output equal to or below 60%, no time limitation plus 5% extra power for governing purposes.
- 4) Limited-time running power 100%, which can be delivered during 500 running h/year, thereof max. 300 running h/year continuously, no overload permissible; the required extra power for governing purposes must be taken into account however.
- 5) Taking into account typical generator efficiency (0.9) and power factor cos (φ) = 0.8.
- 6) Fuel specification: see operation manual.

The values given in this data sheet are for information purposes only and not binding. The information given in the offer is decisive.

► Dimensions

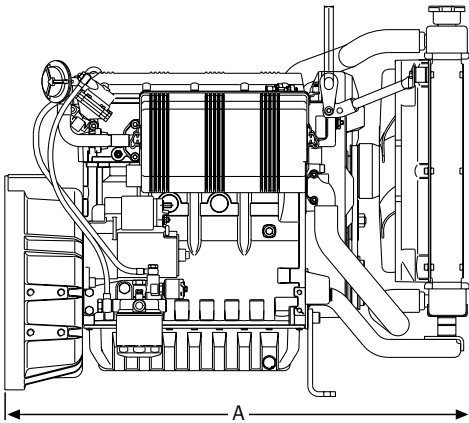
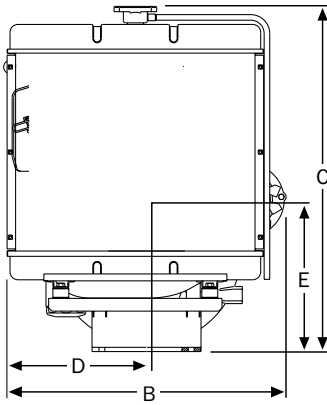

Engine type		A	B	C	D	E
F2M 1008	mm	561	450	591	146	242.5
F3M 1008	mm	680	491	637	146	242.5
F4M 1008	mm	763	491	637	146	242.5
BF4M 1008	mm	763	531	637	146	242.5

► Standard specification

Standard engine:	Basic parts
Cooling system:	Cooling system Pusher-type fan Guard for fan and V-belt drive
Exhaust system components:	Exhaust manifold with counterflange (NA engines) Turbocharger (air inlet at fan end) with bend (exhaust) Exhaust silencer (loose)
Filter:	Dry air cleaner (NA engines: mounted / TC engines: loose) Restriction indicator (loose) Fuel filter
Governor:	Mech. governor
Flywheel:	Flywheel for 6.5" connection $J = 0.269 \text{ kgm}^2$ for $n = 1500 \text{ min}^{-1} / 1800 \text{ min}^{-1}$ $J = 0.108 \text{ kgm}^2$ for $n = 3000 \text{ min}^{-1} / 3600 \text{ min}^{-1}$
Adapter housing:	SAE 5 housing
Engine mounting:	Rigid engine mounting, front end
Engine electrics:	Electric engine shutdown (de-energized for shutdown) Starter motor 12 V, 1.1 kW Alternator 14 V, 35 A Oil pressure monitoring, switch Coolant temperature monitoring, switch Preheating system (preheating controller), pin-type heater plugs Without cable harness and without connector
Miscellaneous:	Without painting Without operation manual



Knowing it's DEUTZ.

DEUTZ AG

Deutz-Mülheimer Str. 147-149
D-51057 Köln
Phone: + 49 (0) 2 21-8 22-0
Fax: + 49 (0) 2 21-8 22-25 68
Internet: <http://www.deutz.de>
E-mail: Info@deutz.de